

The background features a repeating pattern of green and white geometric shapes, resembling stylized leaves or petals. The shapes are arranged in a radial pattern, creating a dynamic and modern aesthetic. The central focus is a white square with rounded corners, containing the product information.

COSATTO[®]
baby stuff with personality[®]

402

PUSHCHAIR



NITTY GRITTY









Important: Keep these instructions for future reference.







Important safety Information

General:

- The pushchair is suitable for children from birth up to a maximum user weight of 15kg.
- **WARNING:** Never leave your child unattended.
- **WARNING:** Ensure that all the locking devices are engaged before use.
- **WARNING:** To avoid injury ensure that your child is kept away when unfolding and folding this product.
- **WARNING:** Do not let your child play with this product.
- **WARNING:** This product is not suitable for running or skating.
- **WARNING:** Always use the restraint system.
- **WARNING:** Always use the crotch strap in combination with the waist belt.
- **WARNING:** To avoid risk of injury from burning, do not place hot beverage on cup holder.
- Do not use replacement parts or accessories other than those approved by Cosatto.
- A basket is provided for the carriage of 2kg of goods, evenly distributed.
- Any additional load attached to the handle or on the back of the backrest or on the sides of the vehicle will affect the stability and safety of the vehicle.
- Do not use a platform with this product as it may render the product unsafe.
- Always apply the brake when placing or removing a child from vehicle.
- Never carry a second child on the product.
- This product complies with BS EN 1888:2012.
- Use the seat in the most reclined position for new born babies until they can sit up unaided.
- Ensure your child wears a correctly fitted and adjusted harness at all times. D-rings are provided for the attachment of a separate safety harness approved to BS EN 13210 should this be required.

Visual language Key:

	Refer to warning XX
	Correct action
	Incorrect action
	Audible sound
	Repeat action x times
	General action arrow

	Lock
	Unlock
	Press and hold
	Check
	Continue to step XX
	Repeat on other side

Parts

1. Chassis
2. Rear wheel x2
3. Front wheel x2
4. Hood
5. Bumper bar
6. Footmuff
7. Raincover
8. Raincover bag
9. Cup holder

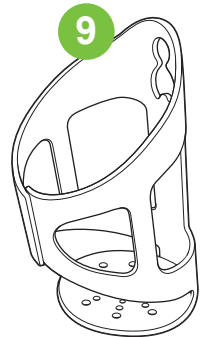
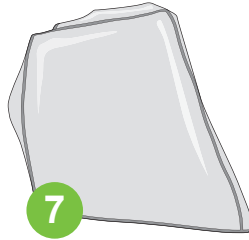
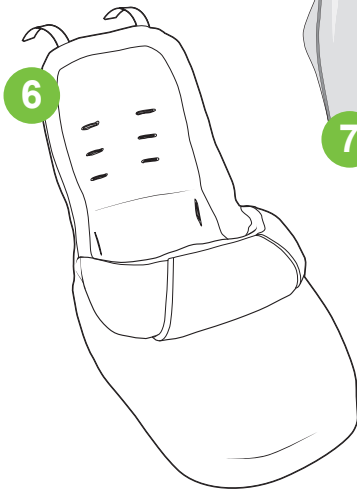
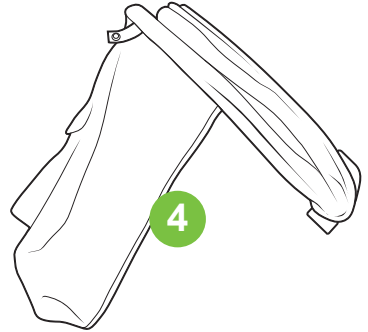
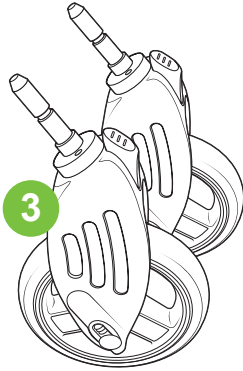
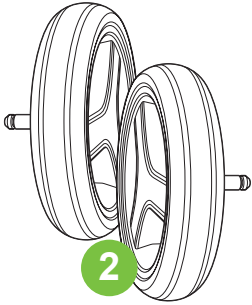
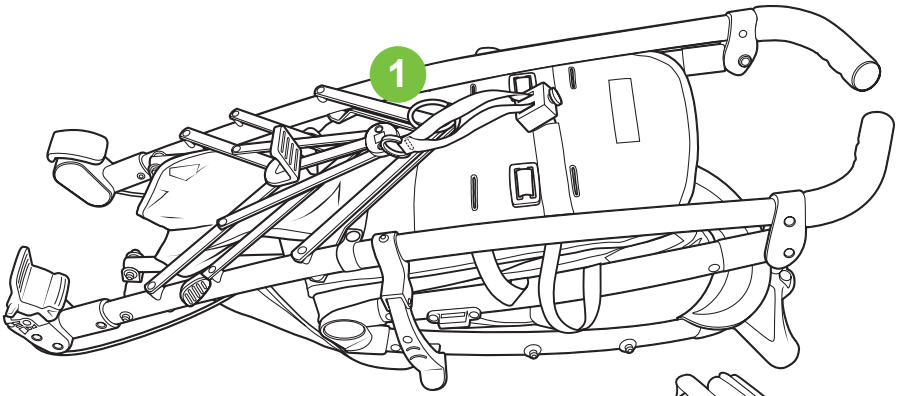

Replacement Parts:

The replacement parts shown below are available for your product. For UK & Ireland customers, order through our website: <http://www.cosatto.com/service-centre/spares>
For customer outside UK & Ireland, contact information for your local distributor can be found on <http://www.cosatto.com/stockists>

If you require any further assistance, please contact us at cuddle@cosatto.com

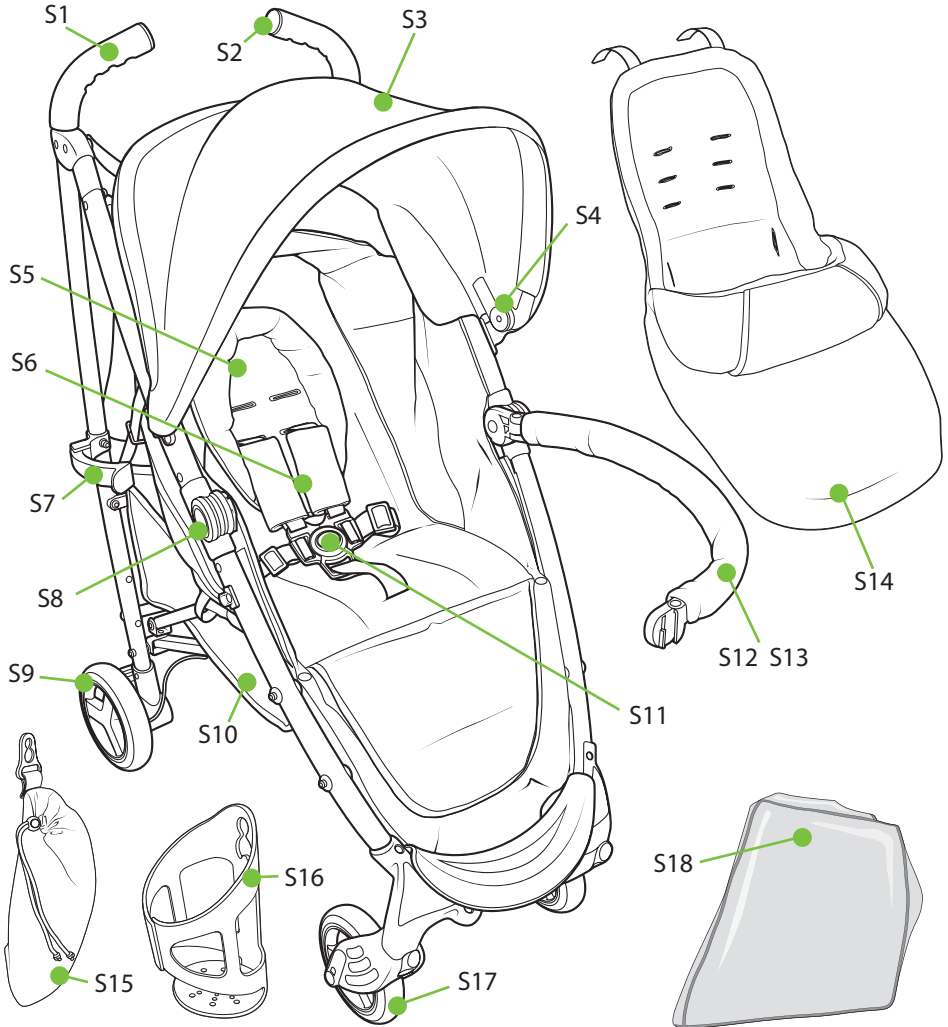

S1: Foam handle

S2: Handle pip

S3: Hood fabric

S4: Hood frame

S5: Headhugger

S6: Chest pads (pair)

S7: Auto lock

S8: Elbow joint badge

S9: Rear wheel

S10: Basket

S11: Harness

S12: Bumper bar

S13: Bumper bar cover

S14: Footmuff

S15: Raincover bag

S16: Cup holder

S17: Front wheel

S18: Raincover

Care & Maintenance:

Your pushchair has been designed to meet comprehensive safety standards, and with correct use and maintenance will give many years of trouble free performance.

The chassis is strong but will weaken should the back wheels be bumped down stairs or kerbs. Continual impact will cause damage.

If your child wears hard shoes these might damage the soft fabric.

Store your pushchair in a dry, safe place.

Storing a damp pushchair will encourage mildew to form, so after exposure to damp conditions, dry off with a soft cloth and allow to dry thoroughly before storing.

Do not leave the pushchair in sunlight for prolonged periods - some fabrics may fade.

Regularly inspect the locking devices, brakes, wheels, harness assembly, catches, seat adjusters, joints and fixtures to ensure they are secure and in full working order. They should move freely at all times.

Cosatto products are designed to operate with minimum maintenance, however regular lubrication of moving parts will extend the life of your pushchair and make opening and folding easier.

Should parts of your pushchair become stiff or difficult to operate, apply a light application of a spray lubricant e.g. silicone. Do not use oil or grease.

Wheels are subject to wear and should be replaced if necessary.

Your pushchair should be serviced and reconditioned before using it for a second baby, or after 18 months, whichever is the sooner.

Hood may be cleaned by sponging lightly using warm water and a mild detergent.

Refer to the wash care label on soft goods for cleaning instruction.

Plastic and metal parts may be sponged clean with warm water and a mild detergent.

Never clean with abrasive, ammonia based, bleach based or spirit type cleaners.

Fitting & Operation information

Please refer to the following diagrams:

Wheels

1

Fitting

2

Removing

Pushchair

3

Opening

Release auto lock **(1)** then pull the handles upwards **(2)**.

Press down on the locking lever **(3)** until a 'Click' is heard and the release arm **(4)** is locked in place.

Check the chassis has locked in place.

Brake

4

Applying

5

Releasing

Front wheel swivel lock

6

Applying

7

Releasing

Harness

8

Opening

9

Closing

10

Adjusting the strap length

Slide the strap adjustor to suitable length **(1, 2 & 3)**.

11

Adjusting the shoulder strap position

12

Removing

Push shoulder strap retainer through backrest (1).

Push crotch strap retainer through seat (2).

Rotate "C" clip to expose its opening (3) and slide waist strap out of clip (4).

Refitting is a reversal of this procedure.

Bumper bar

13

Fitting

14

Opening/Removing

Calf support

15

Opening

Hood

16

Fitting

Push the brackets onto the mounts on the chassis (1).

Attach the fabric fasteners to the inside of the seat unit (2).

Attach the fabric fasteners to the outside of the seat unit (3).

Fit the rear of the hood behind the backrest and attach the fabric fastener (4).

Attach the straps to the handle hinges (5).

17

Opening

18

Extending

19

Using the viewing window flap

20

Using the hood pocket

21

Closing

22

Removing

Removal is a reversal of step 16.

23

Fabric removal

Using a ball point pen push in the button on the arm (1) then pull the arm out of the hinge unit (2). The buttons are on the outside on the lower arms and the inside on the upper arms. Pull the arms out of the hood fabric (3).

24

Refitting

Backrest recline

25

Lowering

26

Raising

Basket

27

Removing

Footmuff

28

Fitting

Open the harness (9) and remove chest pad & headhugger (1). Push the harness straps through the footmuff (2). Attach the footmuff fabric fasteners to the rear of the backrest (3). Refit headhugger & chest pads then close the harness.

Raincover

29

Fitting

Drinks holder

30

Fitting

Raincover

31

Fitting

Pushchair

32

Closing

Ensure backrest is in the upright position (26). Press down on the release arm (1) then pull the ring upwards (2). Push the handles forwards (3) until the auto lock engages (4).















Importante: Guarde estas instrucciones para futura consulta.

Información de seguridad importante

General:

- La sillita está indicada desde el nacimiento y para niños de un máximo de 15kg.
- **ADVERTENCIA:** Supervise al niño en todo momento.
- **ADVERTENCIA:** Asegúrese de que todos los dispositivos de bloqueo estén conectados antes de usar.
- **ADVERTENCIA:** Para evitar lesiones, asegúrese de mantener alejado al niño al plegar y desplegar este producto.
- **ADVERTENCIA:** No permita que el niño juegue con este producto.
- **ADVERTENCIA:** Este producto no está indicado para correr o patinar.
- **ADVERTENCIA:** Use siempre el sistema de retención.
- **ADVERTENCIA:** Use siempre la correa de entrepierna en combinación con el cinturón.
- **ADVERTENCIA:** Para evitar el riesgo de quemaduras, no coloque bebidas calientes en el portavasos.
- No use piezas de repuesto ni accesorios que no sean los aprobados por Cosatto.
- Se incluye una cesta para el transporte de 2 kg de productos, distribuidos uniformemente.
- Cualquier carga adicional acoplada al mango, a la parte trasera del respaldo o a los lados del vehículo afectará a su estabilidad y seguridad.
- No use una plataforma con este producto, ya que podría afectar a su seguridad.
- Accione siempre el freno al colocar o quitar al niño del vehículo.
- No lleve nunca a un segundo niño en el vehículo.
- Este producto cumple con la normativa BS EN 1888:2012.
- Use el asiento en la posición más reclinada ("acostada") para recién nacidos hasta que se puedan incorporar sin ayuda.
- Asegúrese de que el niño lleve un arnés correctamente equipado y ajustado en todo momento. Las hebillas en forma de D del arnés existente se suministran para acoplar un arnés de seguridad separado aprobado por la norma BS EN 13210 de ser necesario.

Clave de lenguaje visual

	Consulte la advertencia XX		Bloquear
	Acción correcta		Desbloquear
	Acción incorrecta		Pulsar y mantener pulsado
	Sonidos		Comprobar
	Repetición de la acción (cuántas veces)		Ir al paso XX
	Flecha de acción general		Repetir en el otro lado

Piezas

1. Chasis
2. Rueda trasera x2
3. Rueda delantera x2
4. Capota
5. Barra de protección
6. Cubrepies
7. Cubierta para la lluvia
8. Bolsa de la cubierta para la lluvia
9. Portabebidas

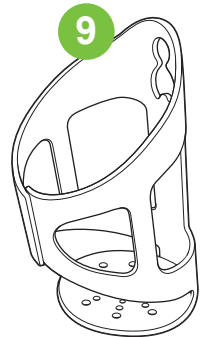
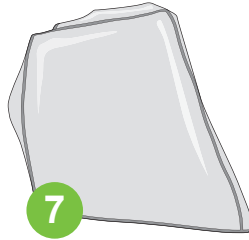
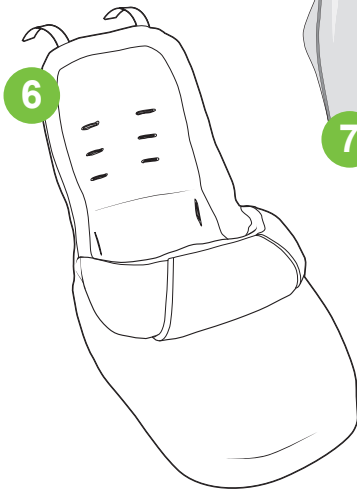
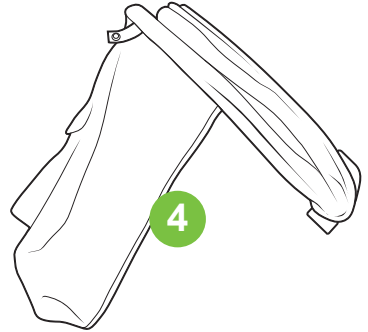
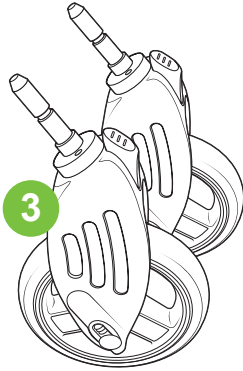
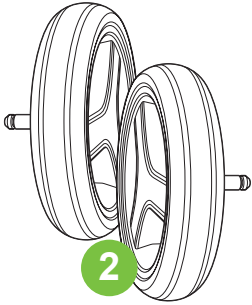
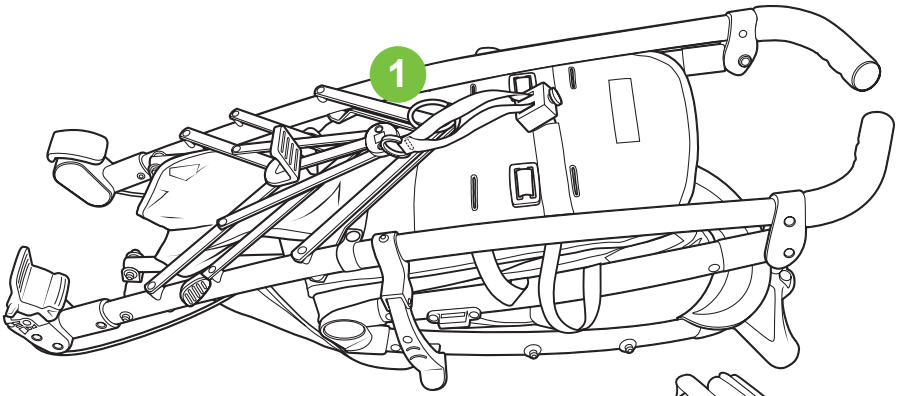

Recambios:

Disponemos de todos los recambios listados a continuación para su producto. Para los clientes del Reino Unido e Irlanda, por favor realicen sus pedidos a través de nuestros sitio Web: <http://www.cosatto.com/service-centre/spares>

Para los clientes de fuera del Reino Unido e Irlanda, en <http://www.cosatto.com/stockists> encontrarán los datos de contacto de sus distribuidores locales.

Si necesita asistencia adicional, por favor póngase en contacto con nosotros en cuddle@cosatto.com

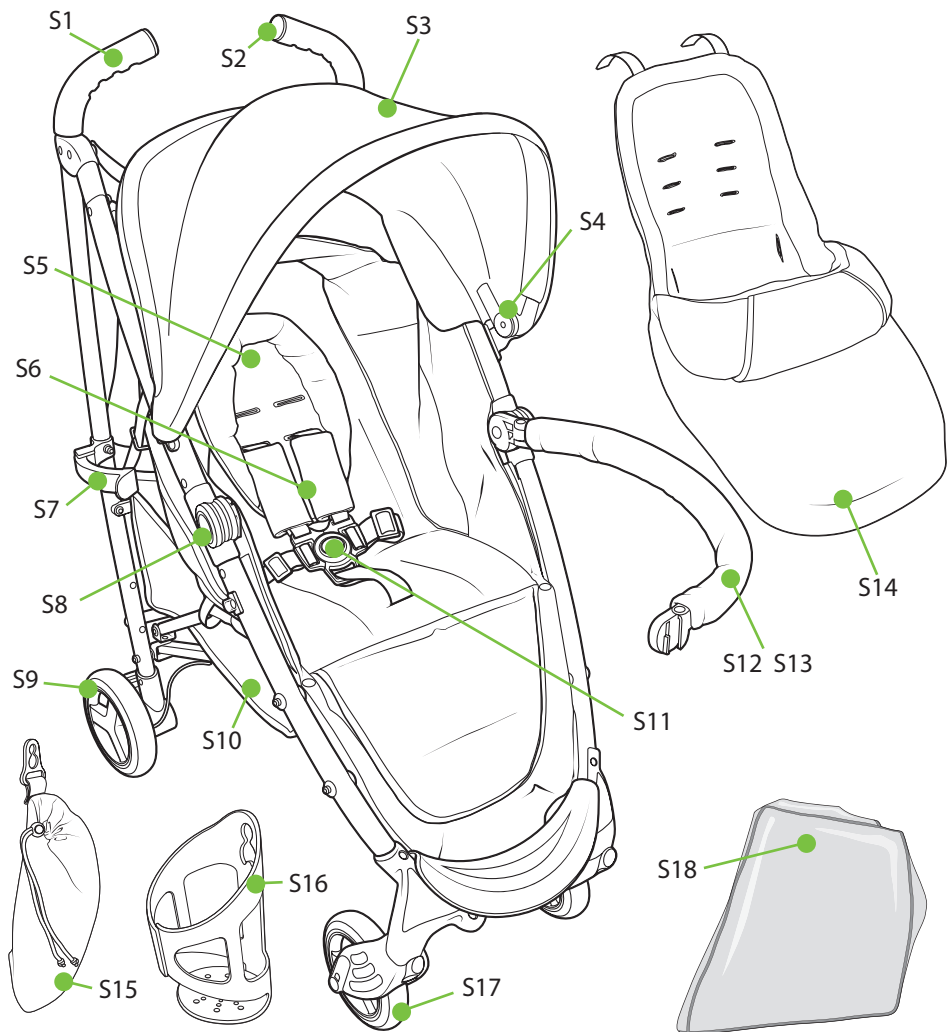

S1: Asa de espuma
S2: Extremo del asa
S3: Tela de la capota
S4: Bastidor de la capota
S5: Reposacabezas
S6: Almohadillas para pecho (par)

S7: Bloqueo automático
S8: Etiqueta de la articulación
S9: Rueda trasera
S10: Cesta
S11: Arnés
S12: Barra de protección

S13: Cubierta de la barra de protección
S14: Cubrepiés
S15: Bolsa de la cubierta para la lluvia
S16: Portabebidas
S17: Rueda delantera
S18: Cubierta para la lluvia

Cuidado y mantenimiento:

El cochecito se ha diseñado para satisfacer exhaustivas normas de seguridad y, con un uso y mantenimiento correctos, ofrecerá un rendimiento excelente durante muchos años.

El chasis es resistente, pero se verá afectado si la rueda trasera tropieza con escalones o aceras. Un impacto continuo causará daños.

Si el niño lleva zapatos rígidos, pueden dañar el tejido suave.

Guarde el cochecito en un lugar seco y seguro.

Guardar un cochecito húmedo fomentará el crecimiento de moho, así que, tras exponerlo a condiciones húmedas, séquelo con un paño suave y déjelo secar completamente antes de guardarlo.

No deje el cochecito al sol durante períodos prolongados, ya que podrían decolorarse algunos tejidos.

Inspeccione periódicamente los dispositivos de cierre, frenos, ruedas, conjunto de arnés, retenedores, ajustadores del asiento, juntas y accesorios para cerciorarse de que sean seguros y funcionen correctamente.

Los productos de Cosatto están concebidos para funcionar con un mínimo mantenimiento, no obstante, lubricar de forma periódica las piezas móviles ampliará la vida útil de su cochecito y facilitará la apertura y el plegado.

Si las piezas del cochecito se vuelven rígidas o difíciles de manejar, aplique ligeramente un lubricante en aerosol, p. ej., silicona. No use aceite ni grasa.

Las ruedas están sujetas a desgaste y deberían cambiarse de ser necesario.

Debe realizarse un mantenimiento y reacondicionado del cochecito antes de usarlo para un segundo niño o al transcurrir 18 meses, lo que suceda primero.

La capota puede limpiarse frotando ligeramente con una esponja mojada en agua templada y un detergente suave.

Consulte la etiqueta de limpieza de las piezas textiles para ver las instrucciones de limpieza.

Las piezas de plástico y metal pueden limpiarse frotando con una esponja mojada en agua templada y un detergente suave.

No use nunca limpiadores agresivos con base de amoníaco, lejía o disolventes.

Información relativa a la instalación y el funcionamiento

Consulte los siguientes diagramas:

Ruedas

1

Ajuste

2

Extracción

Cochecito

3

Apertura

Suelte el bloqueo automático **(1)** y tire de las asas hacia arriba **(2)**.

Pise el pedal de bloqueo **(3)** hasta que escuche un clic y el brazo de desbloqueo **(4)** quede bloqueado.

Compruebe que el chasis esté bloqueado.

Freno

4

Aplicación

5

Desbloqueo

Bloqueo de giro de la rueda delantera

6

Aplicación

7

Desbloqueo

Arnés

8

Apertura

9

Cierre

10

Ajuste de la longitud de las correas

deslice el ajustador de las correas hasta una longitud adecuada **(1, 2 y 3)**

11

Ajuste de la posición de la correa de hombro

12

Extracción

Pase la retención de la correa de hombro a través del respaldo (1).

Pase la retención de la correa de la entrepierna a través del asiento (2).

Gire el enganche "C" para dejar a la vista su apertura (3) y saque la correa de la cintura del enganche (4).

Para la colocación, realice el procedimiento contrario.

Barra de protección

13

Ajuste

14

Apertura/Extracción

Apoyo para pantorrilla

15

Apertura

Capota

16

Ajuste

Coloque los enganches en los soportes del chasis (1).

Enganche las sujeciones de tela a la parte interior del asiento (2).

Enganche las sujeciones de tela a la parte exterior del asiento (3).

Coloque la parte trasera de la capota detrás del respaldo y enganche la sujeción de tela (4).

Enganche las correas a las bisagras del asa (5).

17

Apertura

18

Extensión

19

Uso de la solapa de la mirilla

20

Uso del bolsillo de la capota

21

Cierre

22

Extracción

Para la extracción debe realizarse el procedimiento inverso al paso 16.

23

Extracción de la tela

Usando un bolígrafo, pulse el botón del brazo (1) y, a continuación, extraiga el brazo de las bisagras (2).

Los botones se encuentran en la parte exterior de los brazos inferiores y en la parte interior de los superiores. Extraiga los brazos de la tela de la capota (3).

24

Refitting

Reclinación del respaldo

25

Bajada

26

Elevación

Cesta

27

Extracción

Cubrepiés

28

Ajuste

Abra el arnés (9) y extraiga la almohadilla para el pecho y el reposacabezas (1).

Pase las correas del arnés por el cubrepiés (2).

Enganche las sujeciones de tela del cubrepiés a la parte posterior del respaldo (3).

Vuelva a colocar la almohadilla para el pecho y el reposacabezas y cierre el arnés.

Cubierta para la lluvia

29

Ajuste

Portabebidas

30

Ajuste

Bolsa de la cubierta para la lluvia

31

Ajuste

Cochecito

32

Ajuste

Asegúrese de que el respaldo esté en posición vertical **(26)**.

Pise el brazo de desbloqueo **(1)** y, a continuación, tire hacia arriba de la anilla **(2)**.

Tire de las asas hacia adelante **(3)** hasta que se enganche el bloqueo automático **(4)**.















Important : conservez ce mode d'emploi afin de pouvoir le consulter ultérieurement.

Informations importantes de sécurité

Généralités:

- Cette poussette est destinée aux enfants dès la naissance jusqu'à un poids maximum de 15 kg.
- **AVERTISSEMENT:** ne laissez jamais votre enfant sans surveillance.
- **AVERTISSEMENT:** assurez-vous que tous les dispositifs de verrouillage sont enclenchés avant toute utilisation.
- **AVERTISSEMENT:** pour éviter les blessures, tenez votre enfant à l'écart lors du dépliage et du pliage du produit.
- **AVERTISSEMENT:** ne laissez pas votre enfant jouer avec ce produit.
- **AVERTISSEMENT:** ce produit n'est pas adapté pour la course à pied ni le patinage (rollers/skate).
- **AVERTISSEMENT:** utilisez toujours le harnais.
- **AVERTISSEMENT:** associez toujours la sangle d'entrejambe avec la ceinture.
- **AVERTISSEMENT:** Pour éviter tout risque de brûlure, ne placez aucune boisson chaude dans le porte-gobelet.
- Utilisez toujours des pièces de rechange ou des accessoires approuvés par Cosatto.
- Un panier permet le transport de 2 kg d'articles uniformément répartis.
- Toute charge supplémentaire fixée à la poignée, à l'arrière du dossier ou sur les côtés de la poussette peut affecter sa stabilité compromettre la sécurité.
- N'utilisez pas de plate-forme avec ce produit, car celle-ci peut compromettre sa sécurité.
- Appliquez toujours le frein avant de placer ou sortir l'enfant de la poussette.
- Ne placez jamais un deuxième enfant dans la poussette.
- Ce produit est conforme à la norme BS EN 1888:2012..
- Abaissez le dossier au maximum (à plat) pour un nouveau-né, jusqu'à ce qu'il puisse tenir assis seul.
- Assurez-vous que le harnais est toujours correctement positionné et réglé pour votre enfant. Des anneaux en D sont fournis sur le harnais existant pour fixer un autre harnais de sécurité approuvé BS EN 13210, si cela est nécessaire.

Signification des symboles

	Reportez-vous à l'avertissement XX		Verrouillez
	Action correcte		Déverrouillez
	Action incorrecte		Appuyez et maintenez
	Signal sonore		Vérifiez
	Répétez l'action x fois		Passez à l'étape XX
	Flèche d'action générale		Répétez de l'autre côté

Pièces

1. Châssis
2. Roue arrière x2
3. Roue avant x2
4. Capote
5. Barre de protection
6. Chancelière
7. Cape de pluie
8. Sac de la cape de pluie
9. Porte-gobelet

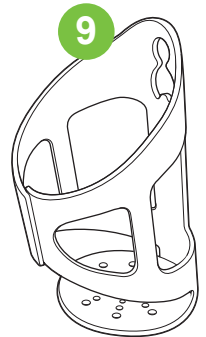
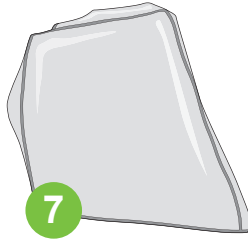
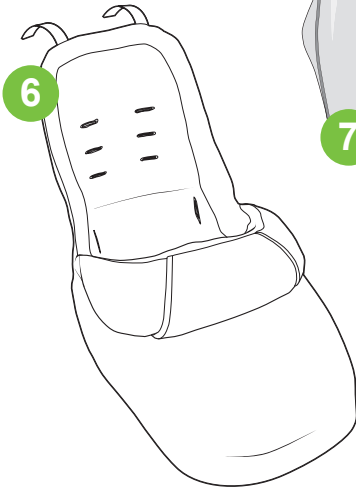
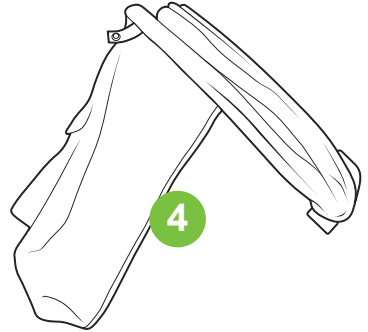
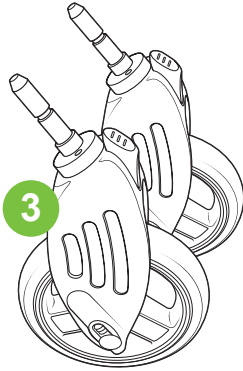
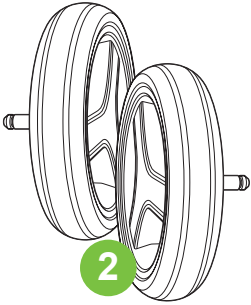
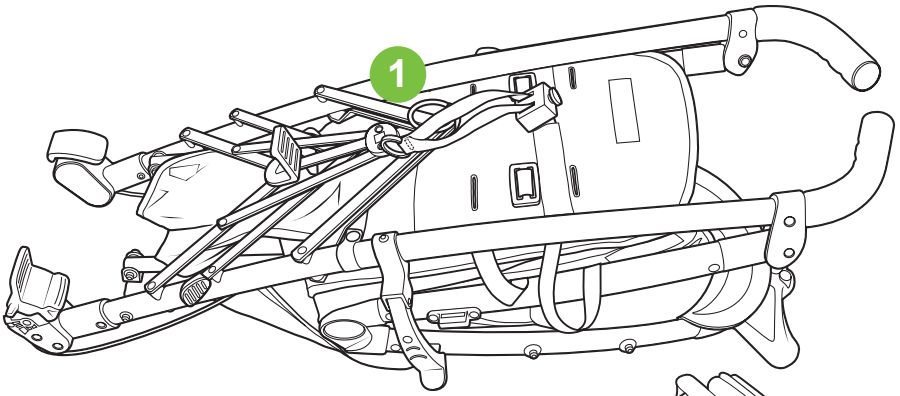

Pièces de rechange:

Les pièces de rechange ci-dessous sont disponibles pour votre produit. Pour le Royaume-Uni et l'Irlande, vous pouvez commander sur notre site : <http://www.cosatto.com/service-centre/spares>

En dehors du Royaume-Uni et de l'Irlande, vous trouverez les coordonnées de votre distributeur sur : <http://www.cosatto.com/stockists>

Si vous avez besoin d'aide, n'hésitez pas à nous écrire à cuddle@cosatto.com

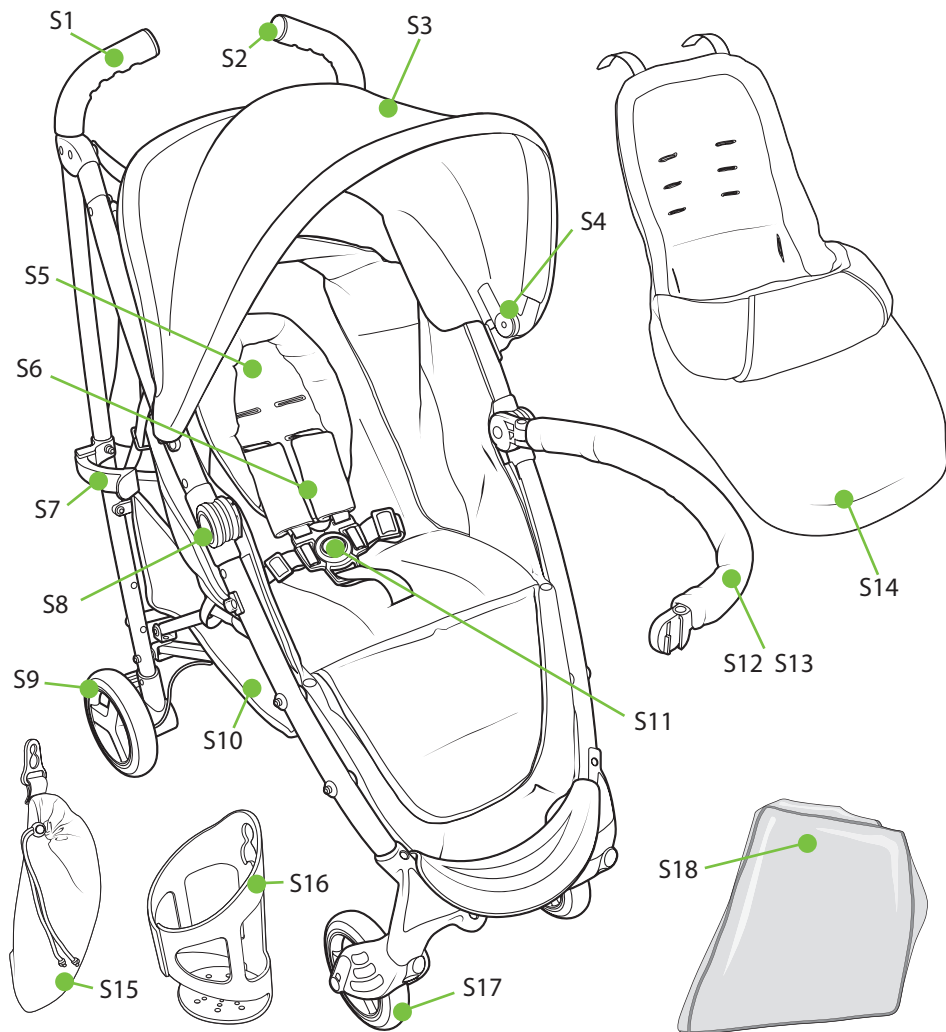

S1: Poignée en mousse
S2: Extrémité de poignée
S3: Tissu de capote
S4: Armature de capote
S5: Cale-tête
S6: Rembourrages de bretelle (paire)

S7: Dispositif automatique de verrouillage
S8: Plaque d'articulation
S9: Roue arrière
S10: Panier
S11: Harnais
S12: Barre de protection

S13: Tissu de la barre de protection
S14: Chancelière
S15: Sac de la cape de pluie
S16: Porte-gobelet
S17: Roue avant
S18: Cape de pluie

Entretien:

Votre poussette a été conçue pour répondre aux normes de sécurité rigoureuses et une utilisation et un entretien appropriés vous garantiront de nombreuses années d'utilisation sans problème.

Le châssis est robuste, mais il s'affaiblira si la poussette tombe sur les roues arrière en descendant les escaliers ou les trottoirs. Les impacts continuels l'endommageront.

Si votre enfant porte des chaussures dures, celles-ci pourraient endommager le tissu.

Rangez la poussette dans un endroit sûr et sec.

Le rangement de la poussette humide favorise la formation de moisissures. S'il est humide, séchez-le avec un chiffon doux et laissez-le sécher complètement avant de le ranger.

Ne laissez pas la poussette longtemps au soleil ; la couleur de certains tissus peut s'estomper.

Inspecter régulièrement les dispositifs de verrouillage, les freins, les roues, le harnais, les boucles, les attaches, les articulations et les fixations pour vous assurer qu'ils sont sûrs et fonctionnels.

Les produits Cosatto sont conçus pour un entretien minimum, cependant la lubrification régulière des pièces mobiles permettra de conserver votre poussette plus longtemps et facilitera le dépliage et le pliage.

Si des pièces de la poussette deviennent difficiles à manœuvrer, appliquez un léger film de spray lubrifiant, par exemple du silicone. Ne pas utiliser d'huile ni de graisse.

Les roues s'usent et doivent être remplacées si nécessaire.

La poussette doit être inspectée et remise en état avant de l'utiliser pour un deuxième bébé ou après 18 mois (le plus tôt des deux).

La capote peut être nettoyée en l'épongeant légèrement avec de l'eau tiède et un détergent doux.

Les instructions de nettoyage des articles en tissu sont indiquées sur leurs étiquettes de lavage respectives.

Les pièces métalliques et en plastique peuvent être nettoyées en les épongeant avec de l'eau tiède et un détergent doux.

N'utilisez jamais de détergent abrasif ou à base d'ammoniaque, d'eau de Javel ou d'alcool.

Informations d'installation et d'utilisation

Reportez-vous aux schémas suivants:

Roues

1

Installation

2

Retrait

Poussette

3

Ouverture

Libérez le dispositif automatique de verrouillage **(1)**, puis tirez les poignées vers le haut **(2)**.

Appuyez sur la pédale de verrouillage **(3)** jusqu'au « clic » et vérifiez que le bras de libération **(4)** est correctement bloqué.

Assurez-vous que le châssis est correctement bloqué.

Frein

4

Application

5

Libération

Loquet de rotation des roues avant

6

Application

7

Libération

Harnais

8

Ouverture

9

Fermeture

10

Ajustement de la longueur des sangles

Faites glisser la boucle de réglage à la longueur appropriée **(1, 2 et 3)**.

11

Réglage de la hauteur des bretelles

12

Retrait

Passez l'attache de bretelle dans la fente du dossier (1).

Passez l'attache de la sangle d'entrejambe dans la fente du dossier (2).

Tournez l'anneau fendu de façon à voir son ouverture (3), puis faites sortir la sangle de l'anneau (4).

Procédez dans l'ordre inverse pour réinstaller le harnais.

Barre de protection

13

Installation

14

Ouverture/ Retrait

Repose-mollets

15

Ouverture

Capote

16

Installation

Insérez les clips dans les supports du châssis (1).

Attachez les bandes scratch à l'intérieur du siège (2).

Attachez les bandes scratch à l'extérieur du siège (3).

Montez l'arrière de la capote derrière le dossier et attachez les bandes scratch (4).

Accrochez les attaches aux charnières de poignée (5).

17

Ouverture

18

Extension

19

Utilisation du rabat de fenêtre

20

Utilisation de la pochette de capote

21

Fermeture

22

Retrait

Le retrait s'effectue en suivant l'étape 16 en ordre inverse.

23

Retrait de la housse

À l'aide d'un stylo à bille, poussez sur le bouton de verrouillage du bras (1), puis tirez celui-ci hors du montant (2).

Les boutons se trouvent à l'extérieur des bras inférieurs et à l'intérieur des bras supérieurs.

Sortez les bras du tissu de la capote (3).

24

Installation

Inclinaison du dossier

25

Abaisser

26

Relever

Panier

27

Retrait

Chancelière

28

Installation

Ouvrez le harnais 9 et retirez les rembourrages de bretelle et l'appui-tête (1).

Poussez les sangles de harnais au travers du couvre-jambes (2).

Attachez les bandes scratch du couvre-jambes à l'arrière du dossier (3).

Remplacez les rembourrages de bretelle et l'appui-tête, puis fermez le harnais.

Cape de pluie

29

Installation

Porte-gobelet

30

Installation

Sac de la cape de pluie

31

Installation

Poussette

32

Fermeture

Assurez-vous que le dossier est relevé au maximum **(26)**.

Appuyez sur le bras de libération **(1)**, puis tirez l'anneau vers le haut **(2)**.

Poussez les poignées en avant **(3)** jusqu'à l'enclenchement du dispositif de verrouillage automatique **(4)**.







重要提示: 请保留此说明以供未来参考。





重要安全信息

通用:

- 折叠式婴儿车用于从出生至15公斤以下的儿童。
- **警告:** 请勿允许儿童独自留守汽车。
- **警告:** 确保所有锁定装置使用前已安全扣好。
- **警告:** 为避免受伤, 打开和折叠产品时, 确保您的孩子远离它。
- **警告:** 你的孩子切勿无人看管。
- **警告:** 本产品不适合跑步或滑冰。
- **警告:** 请始终使用安全系统。
- **警告:** 请始终使用腰带胯部带结合。
- **警告:** 为避免烫伤不要将热饮料放在饮料架上。
- 请使用Cosatto认可的配件或零件, 因为它们可能使婴儿车安全。
- 提供的篮子为运行中使用, 分布均匀, 达到的最大重量为2公斤。
- 附连到手柄上或靠背后部或在车侧部的任何附加负载将会影响车的稳定性。
- 不要同时与婴儿车使用脚踏板, 因为它可能使婴儿车不安全。
- 抱起和放下婴儿时, 随时使用刹车。
- 切勿在您的婴儿车里座二个小孩。
- 本产品符合BS EN 1888: 2012。
- 为新出生的婴儿将座椅倾斜至适合倾斜的(“平躺”)位置, 直到他们能够独立坐起。
- 确保您的孩子在任何时候都戴着正确安装和调整好的安全绑带。需要时, 在现有安全带的配置上可使用附加D形环添加其它BS EN 13210认可的安全带。

可视化语言键

	参考警告 XX
	正确动作
	错误动作
	可听声
	重复动作 x 次
	一般动作箭头

	锁定
	解锁
	按住
	检查
	继续到第 XX 步骤
	在另一侧重复

零件

1. 框架
2. 后轮胎 x2
3. 前轮胎 x2
4. 罩子
5. 前扶手
6. 脚套
7. 防雨罩
8. 防雨罩袋子
9. 饮料架

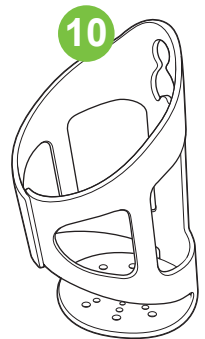
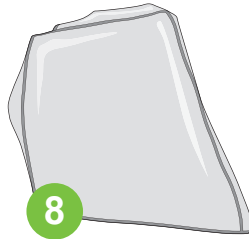
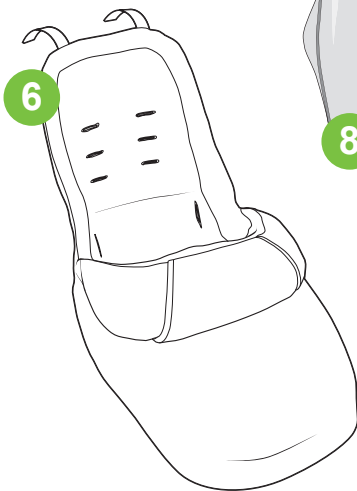
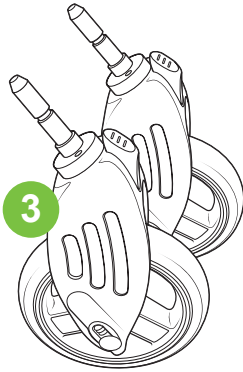
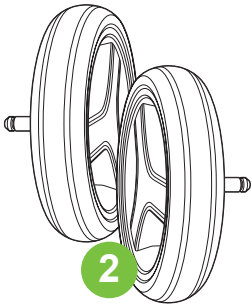
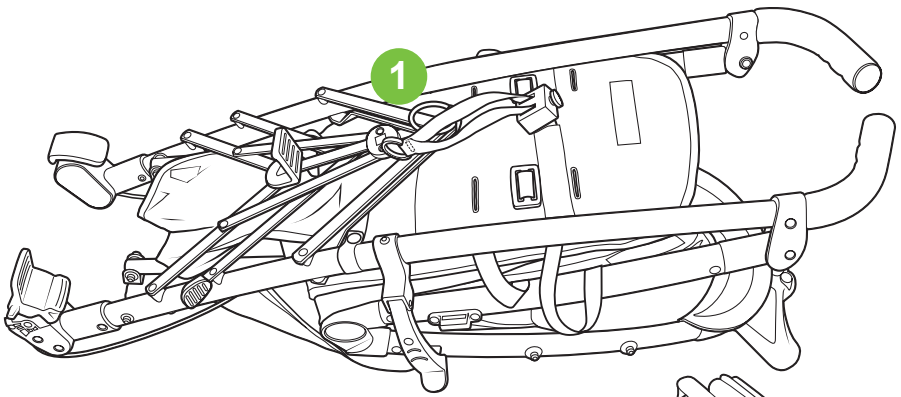

更换部件:

下列更换部件可用于您的产品。对于英国及爱尔兰客户，请通过我们的网站订货：

<http://www.cosatto.com/service-centre/spares>

对于英国和爱尔兰以外的客户，可在这个网站获取您当地经销商的联系信息：

<http://www.cosatto.com/stockists>

如您需要任何其它支持，请致信我们：cuddle@cosatto.com

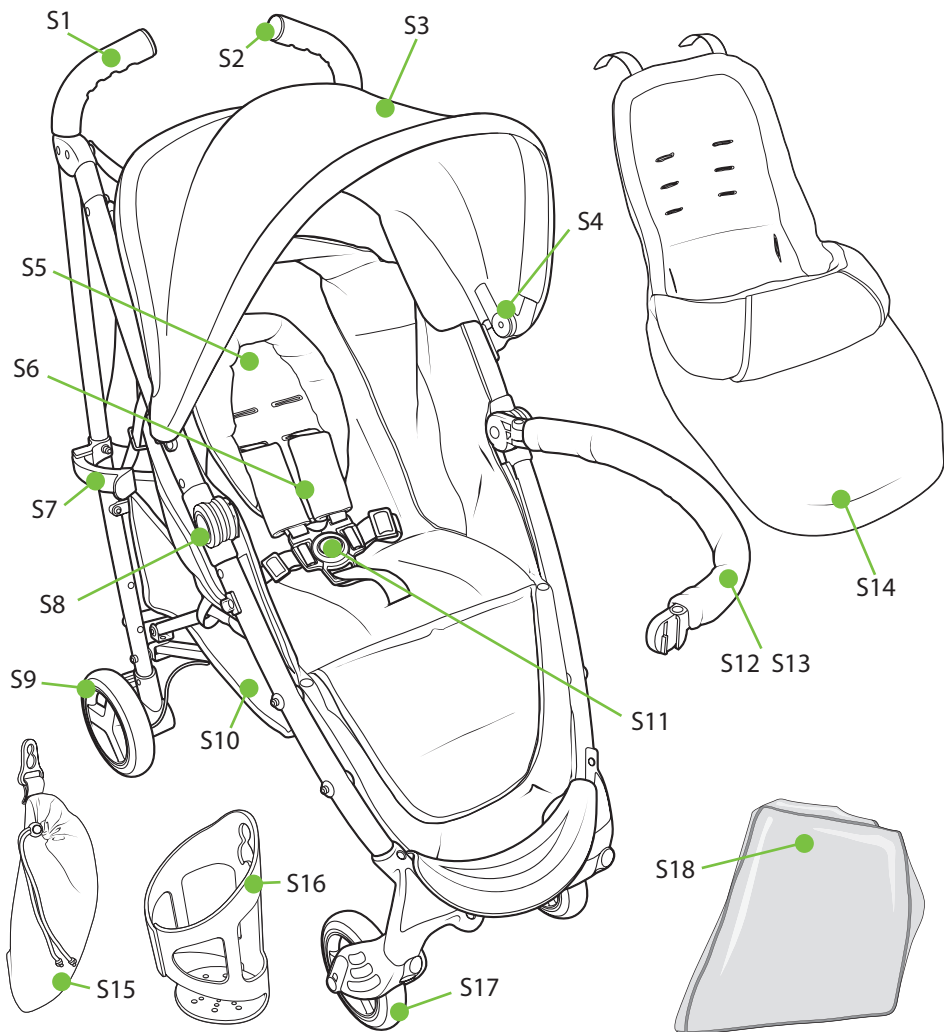

S1: 泡沫手把
S2: 手柄帽
S3: 罩子布料
S4: 罩子架
S5: 护头枕
S6: 肩套 (双)

S7: 自动锁
S8: 肘关节徽章
S9: 后轮胎
S10: 篮子
S11: 安全带
S12: 前扶手

S13: 前扶手套
S14: 脚套
S15: 防雨罩袋子
S16: 饮料架
S17: 前轮胎
S18: 防雨罩

保养与维护:

您的婴儿车的设计是为了满足安全标准，正确的使用和保养会给多年无故障的性能。结实的支架，在上下路边时碰撞后轮胎会产生削弱。持续的碰撞会造成损害。

如果您的孩子穿的硬鞋，可能会损坏柔软的面料。

请将您的婴儿车存放于干燥、安全的地方。

存储潮湿的儿童安全座椅将利于霉菌滋生，因此在潮湿环境中暴露过后，存放之前请用软布彻底擦干。

请避免将婴儿车长期置于阳光下 - 有些面料可能会褪色。

定期检查锁定装置、刹车、轮胎、安全带、门锁、座椅调节带、接头和固定装置，以确保它们安全和良好运作。

Cosatto产品需要最少的维护。但是运动部件需要定期的润滑移动部件会延长您的婴儿车的生命，并使折叠更容易。

如果您的婴儿车部分变得僵硬或难以操作，应用喷雾润滑剂如应用硅胶。不要使用油或油脂。

车轮受到磨损必须要更换。

您的婴儿车应该进行维修和翻新，可接上第二个孩子使用或18个月继续使用为准。

可使用海绵、温水和柔和的清洁剂轻轻清洗棚子。

对于软质产品的洗涤护理指令请参考其各自洗护理标签。

塑料和金属部件，可以用海绵、温水和柔和清洁剂清洗。

不能使用粗厉、基于氨或漂白的清洁剂或带酒精的清洁剂。

安装和操作信息

请参考以下的图:

轮胎

1

制动装置

2

卸掉

婴儿车

3

打开

松开自动锁 (1) 并向上拉把手 (2)。

向下按锁定踏板 (3) 直到听到咔嚓声, 松开把手 (4) 直到其扣好就位。

确保车架扣好就位。

制动装置

4

适用

5

释放

前轮胎旋转锁

6

适用

7

释放

安全带

8

打开

9

关闭

10

调整绑带长度

滑动绑带调节器已达适合长度 (1,2和3)

11

调整肩带位置

12

卸掉

将肩带约束夹穿过靠背（1）。

将胯带约束夹传过座椅（2）。

拧动“C”夹，露出开口（3）并将腰部带子滑出夹子（4）。

反向重复上述步骤并从新安装。

前扶手

13

制动装置

14

打开/卸掉

小腿靠支撑板

15

打开

罩子

16

制动装置

将支架推进车架接口（1）。

将布料紧固带链接到座椅内部（2）。

将布料紧固带链接到座椅外部（3）。

将罩子后部安装在靠背并链接在料紧固带上（4）。

将绑带连到把手合页上（5）。

17

打开

18

伸展

19

使用观察窗帘

20

使用罩子口袋

21

关闭

22

卸掉

反向重复第 16 步骤并移除。

23

移除布料

使用一支笔向里推支架按扣 (1) 并将支架向外拉出合页 (2)。按扣在支架下部外面和支架上部里面。将支架从罩子拉出 (3)。

24

重新装入

靠背倾斜

25

降低

26

抬起

篮子

27

卸掉

脚套

28

安装

打开安全带 9 并移除肩套和护头枕 (1)。

将安全绑带传过脚套 (2)。

将脚套布料紧固带链接到靠背后部 (3)。

重新安装肩套和护头枕再扣紧安全带。

防雨罩

29

安装

饮料架

30

安装

防雨罩袋子

31

安装

婴儿车

32

关闭

确保靠背处于最直立的位置⁽²⁶⁾。向下按压释放按钮 (1) 并向上拉环 (2)。将手柄向前推 (3) 直到自动锁锁住 (4)。

1

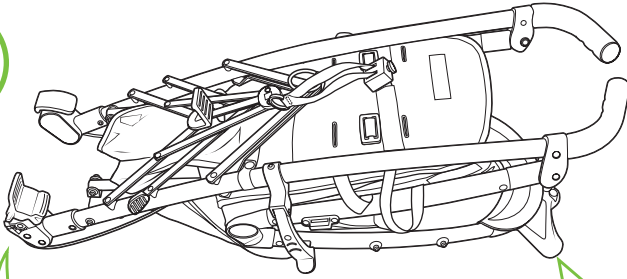

CLICK!

2

1

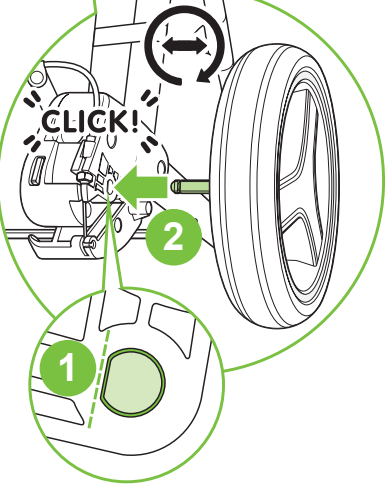

CLICK!

3

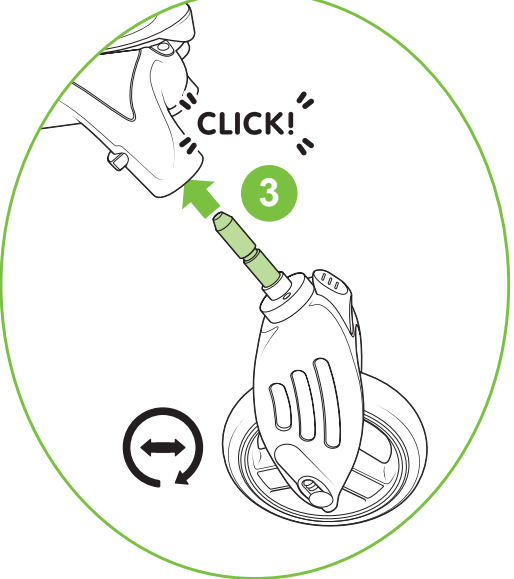

2

2

1

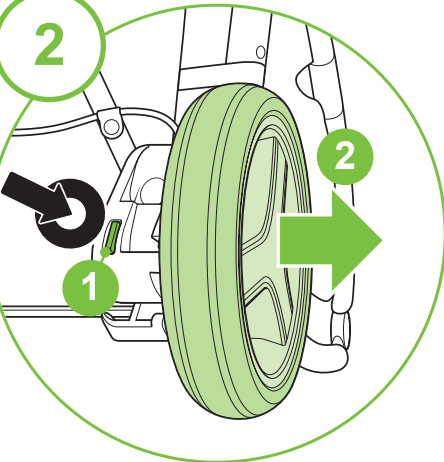

3

4

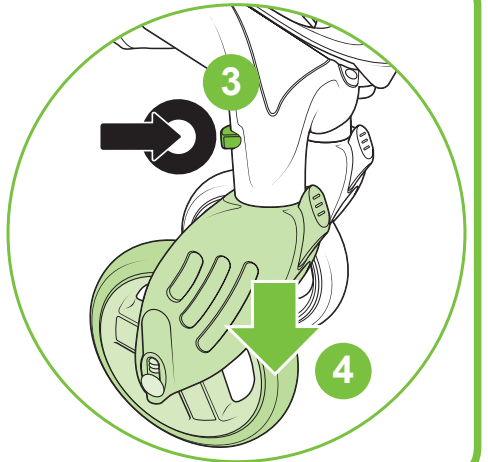

3

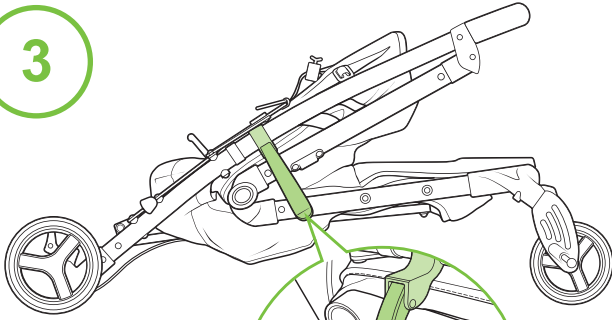

1

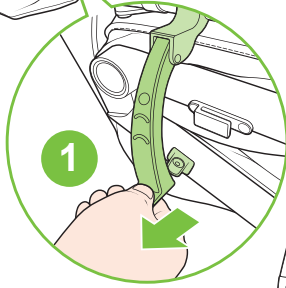

2

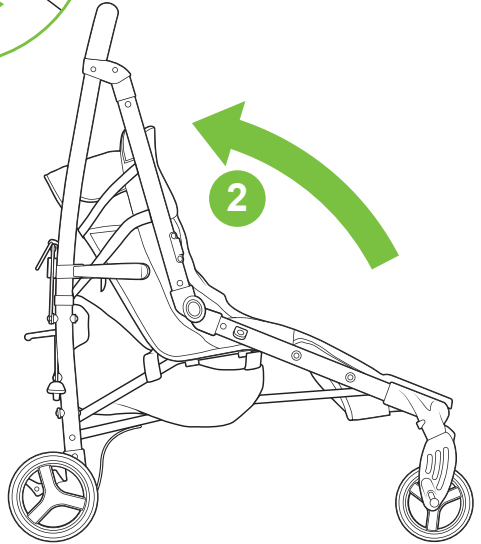

3

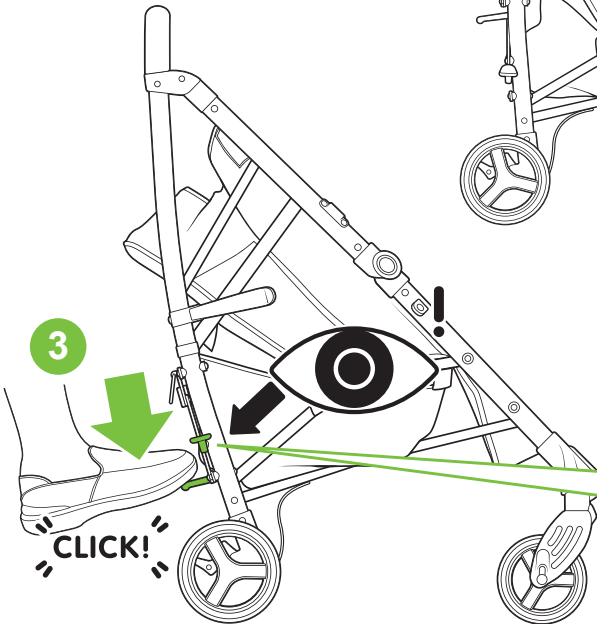

CLICK!

4

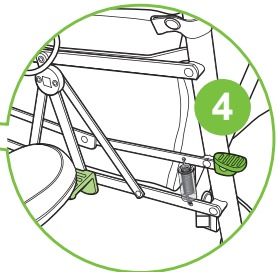

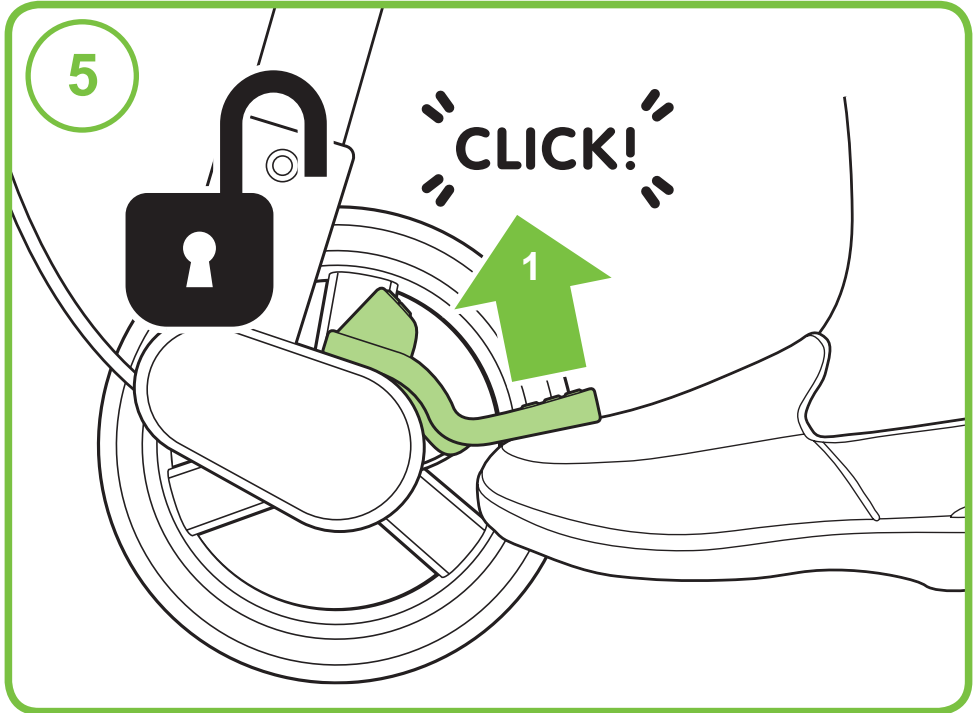
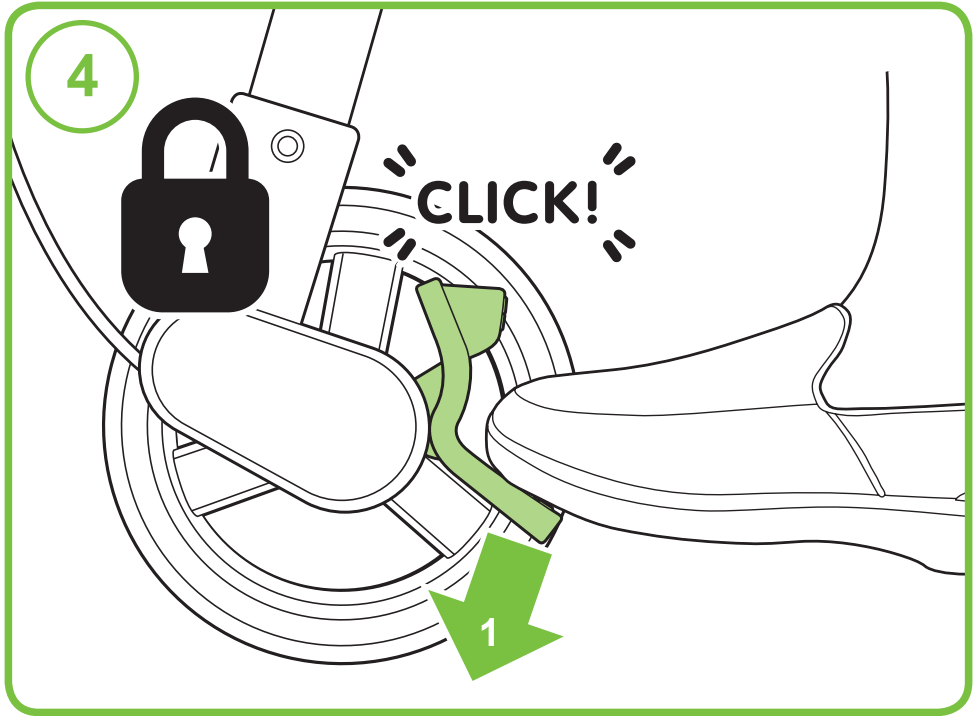

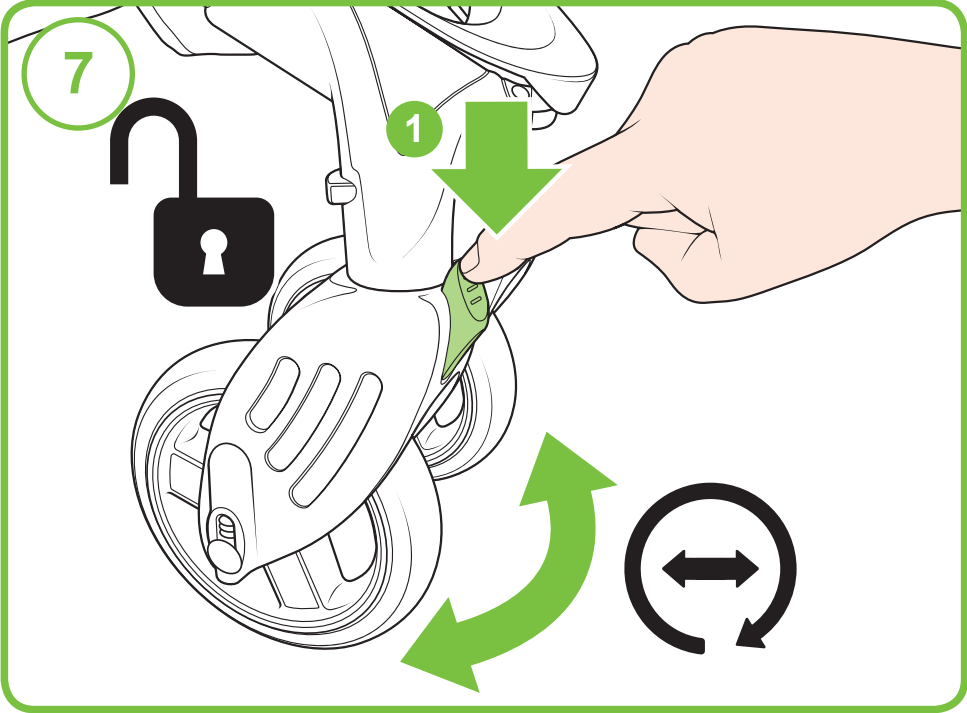
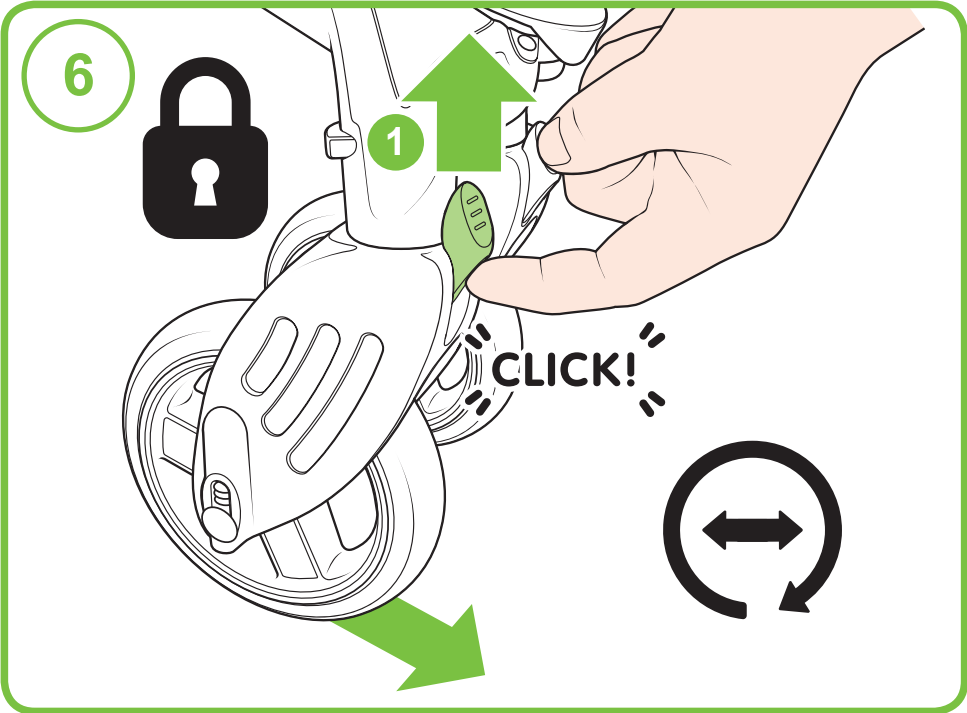

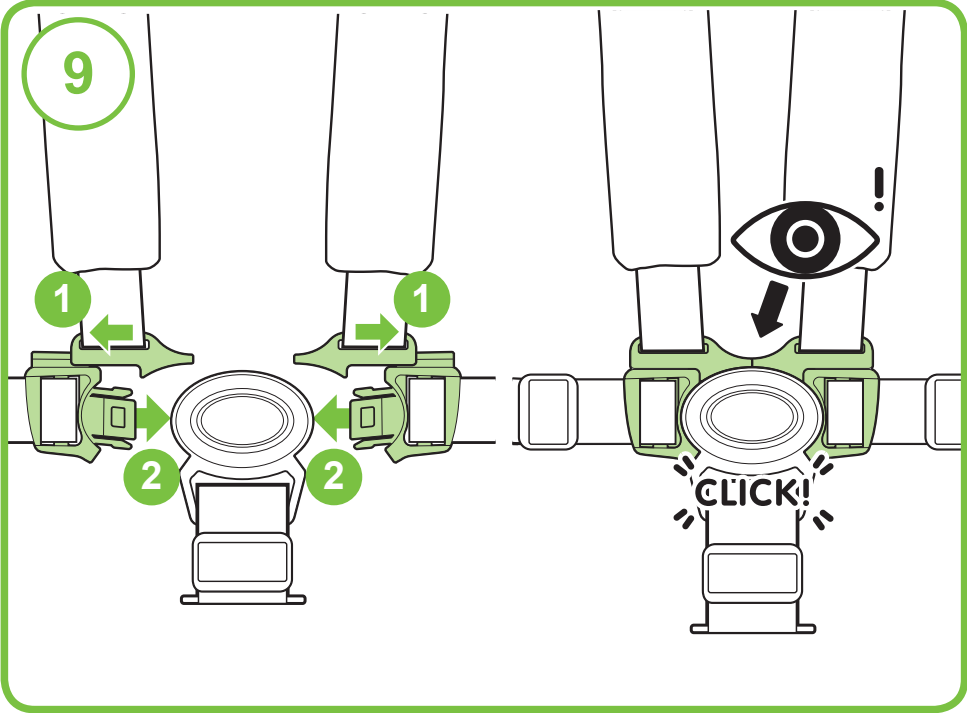
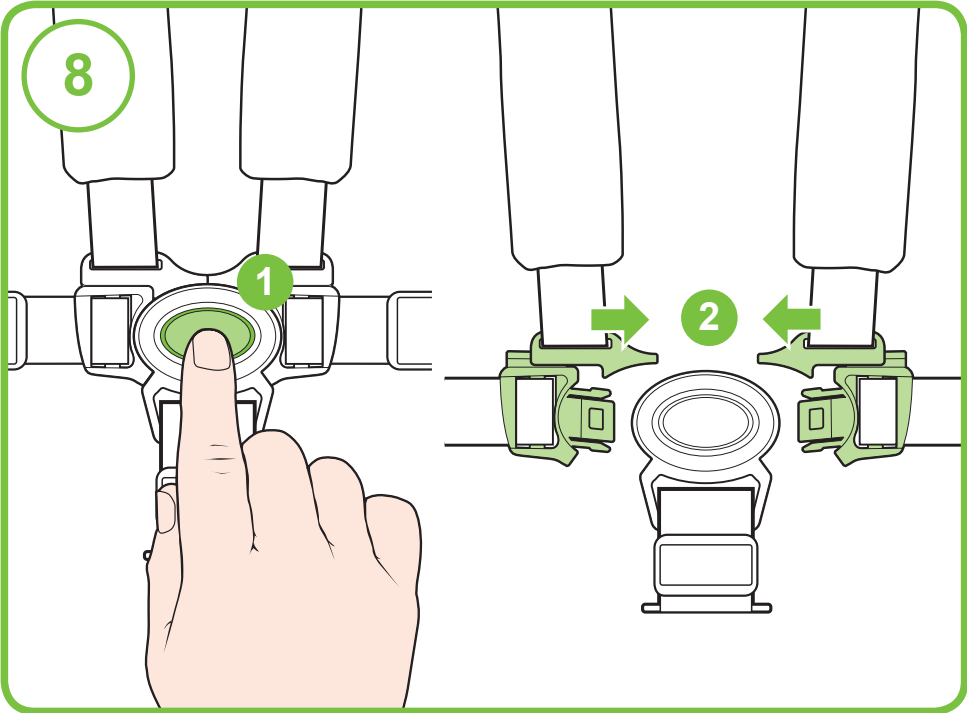

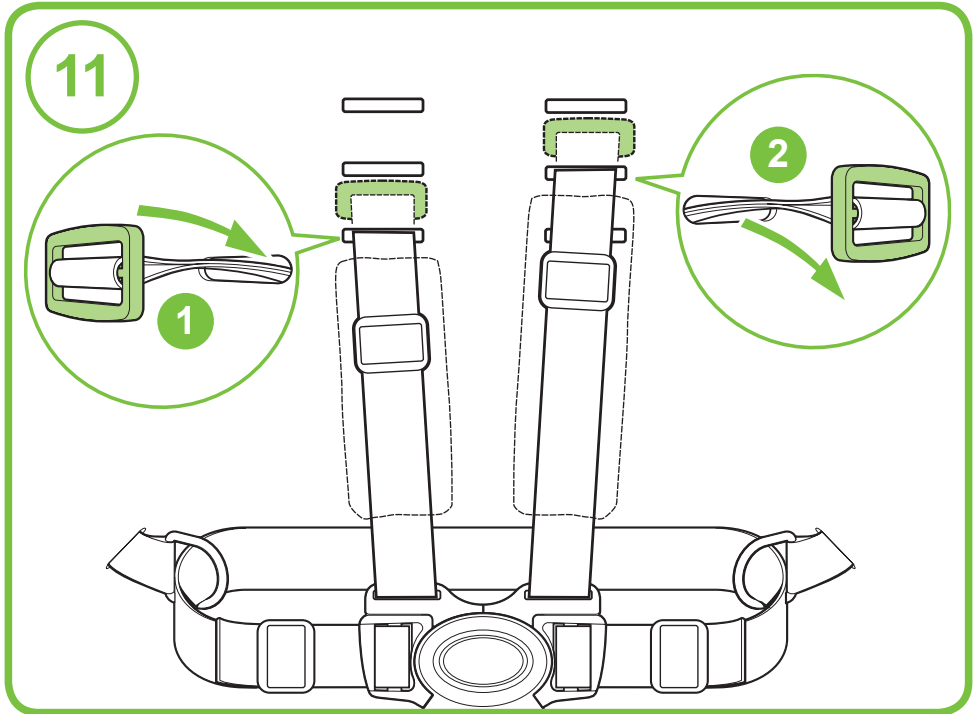
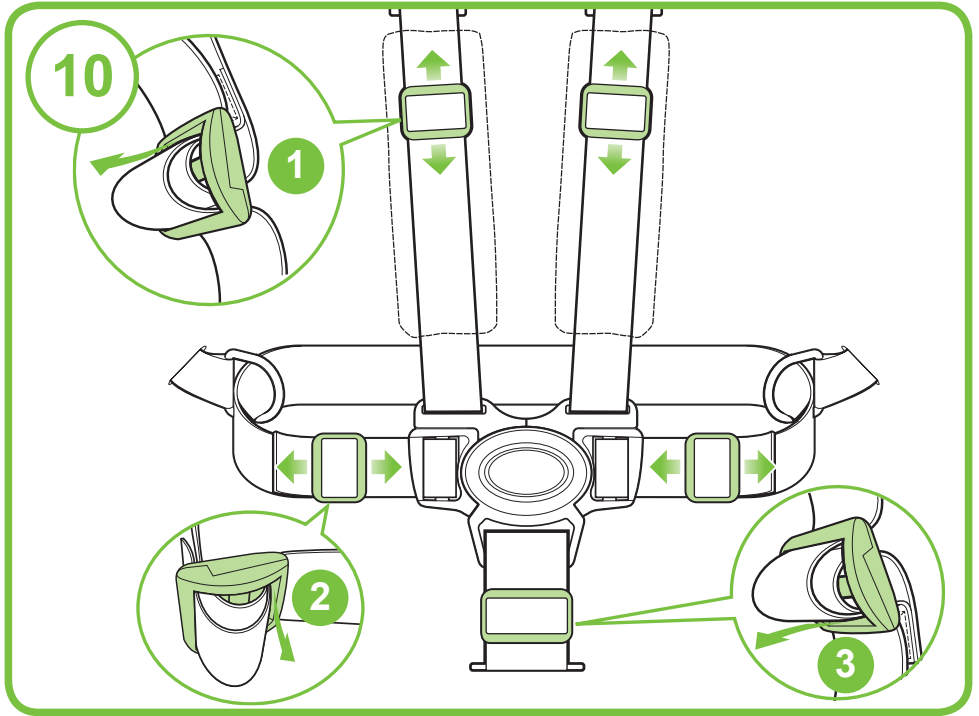

12

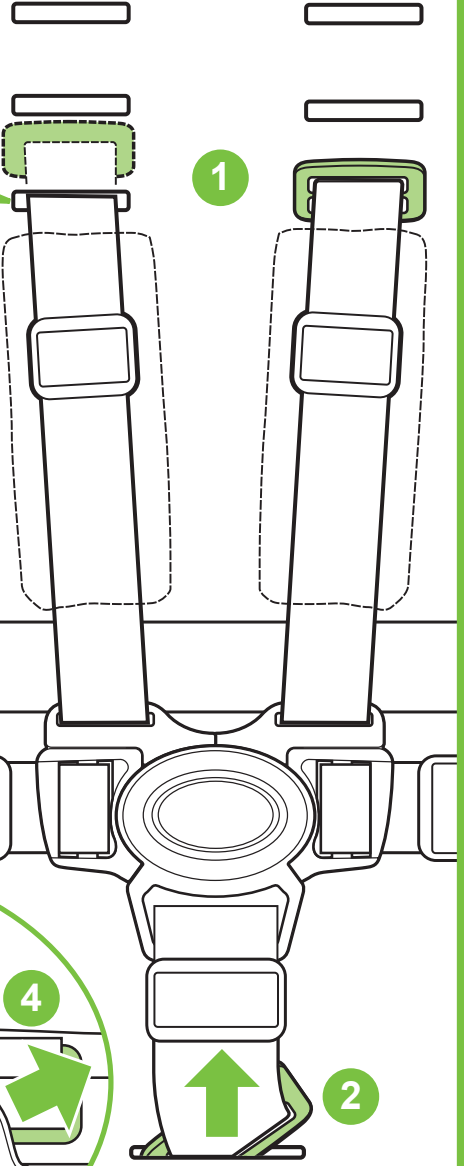
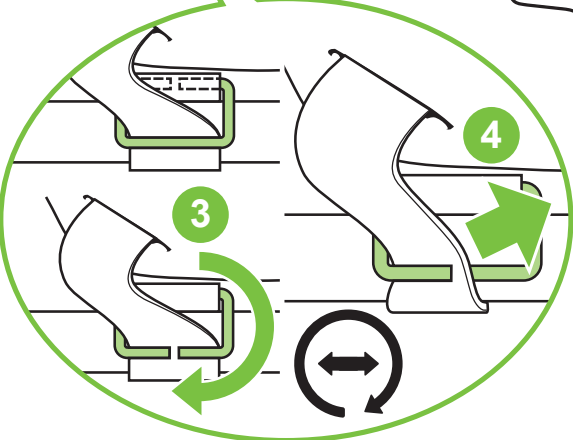
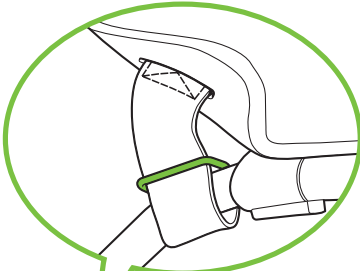
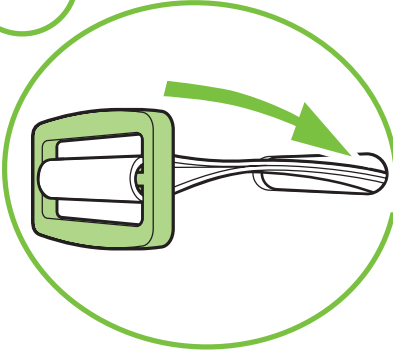

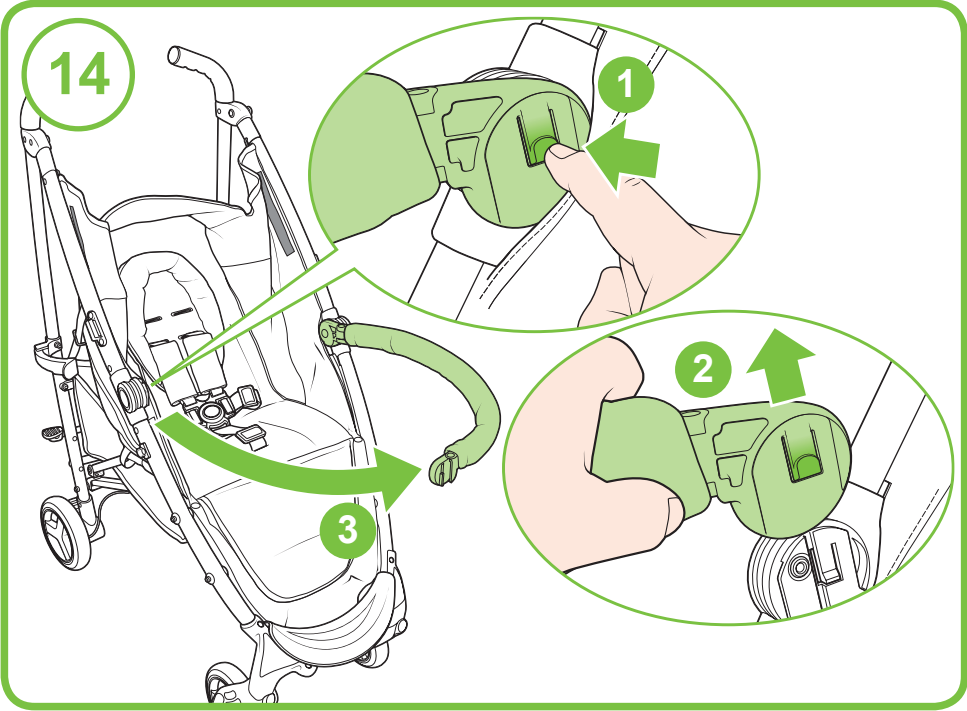
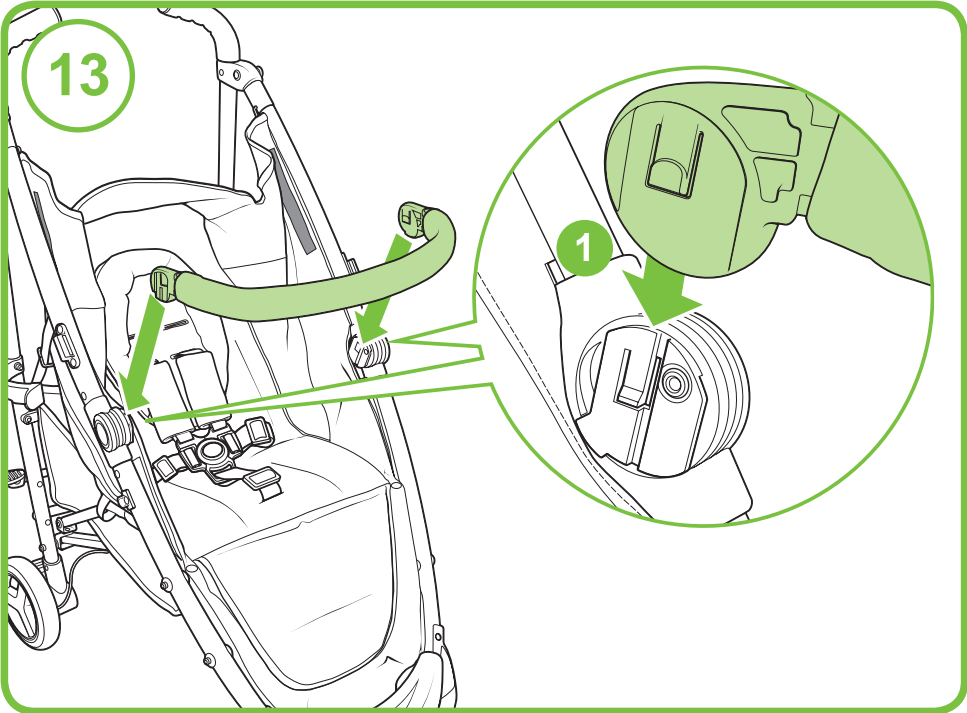

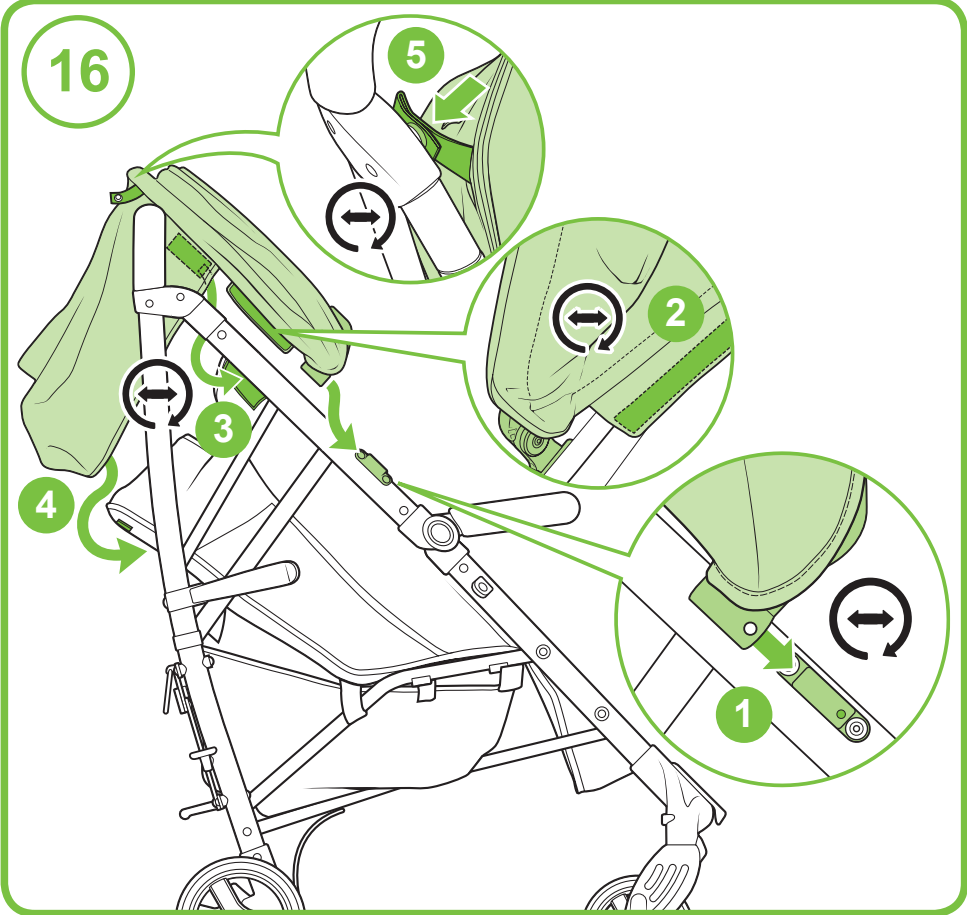
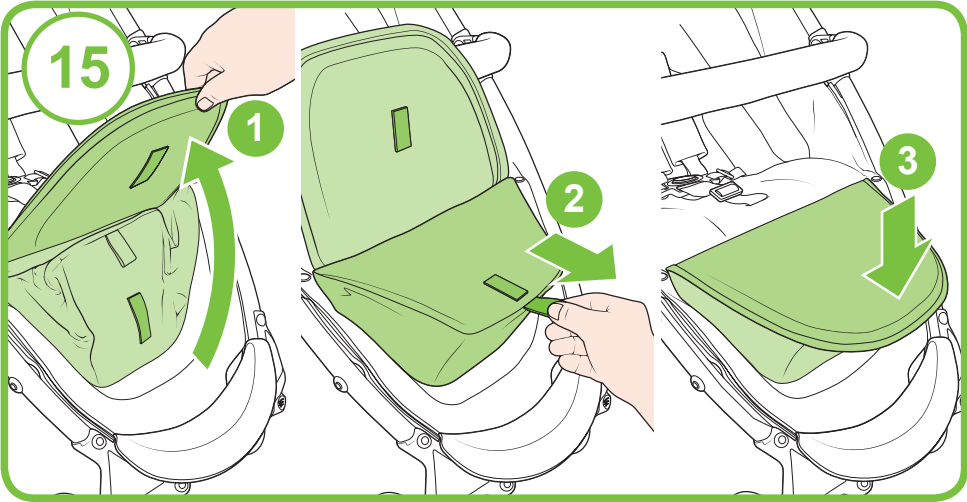

17

1

2

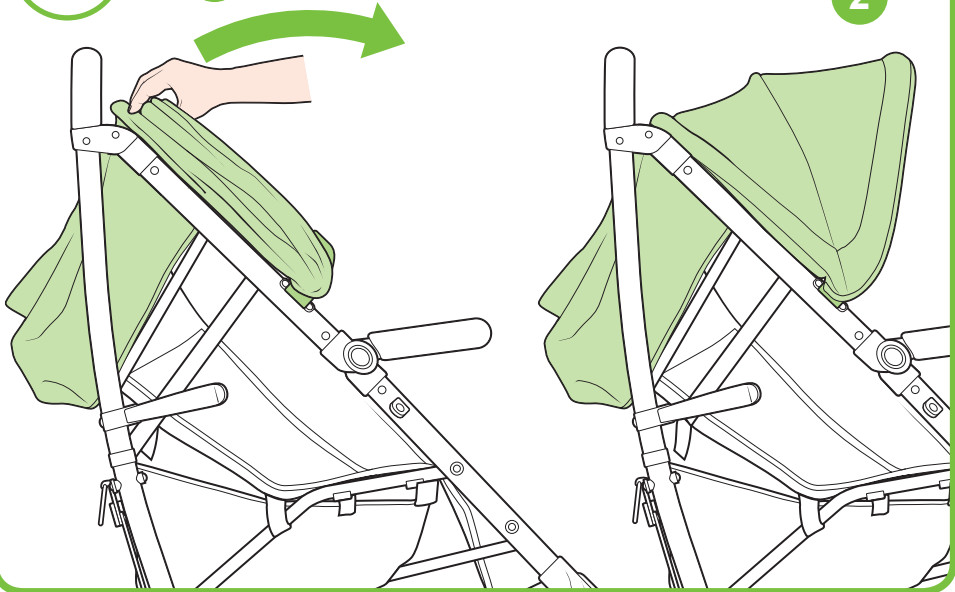

18

1

2

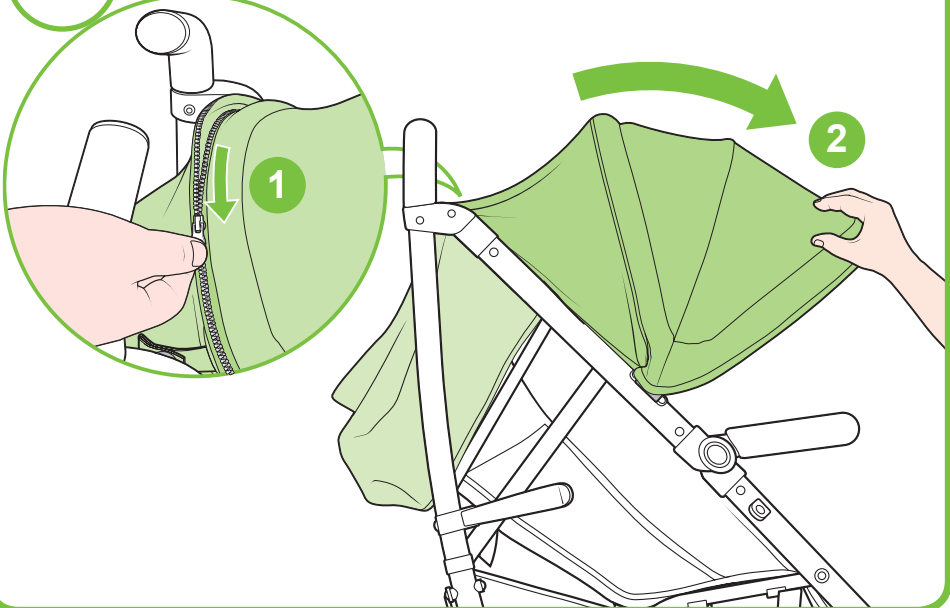

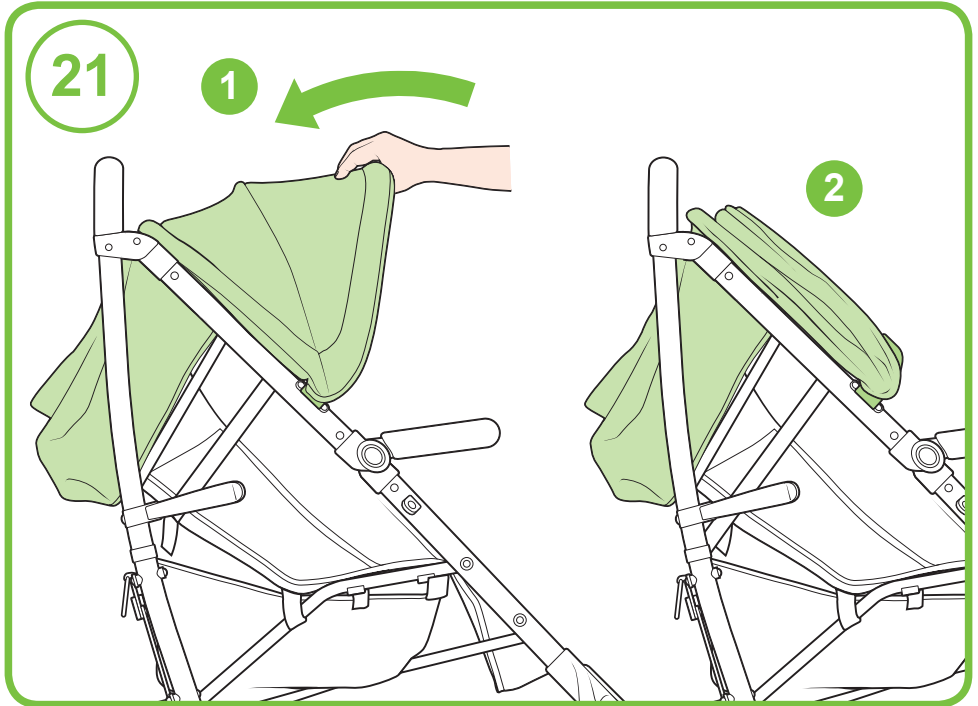
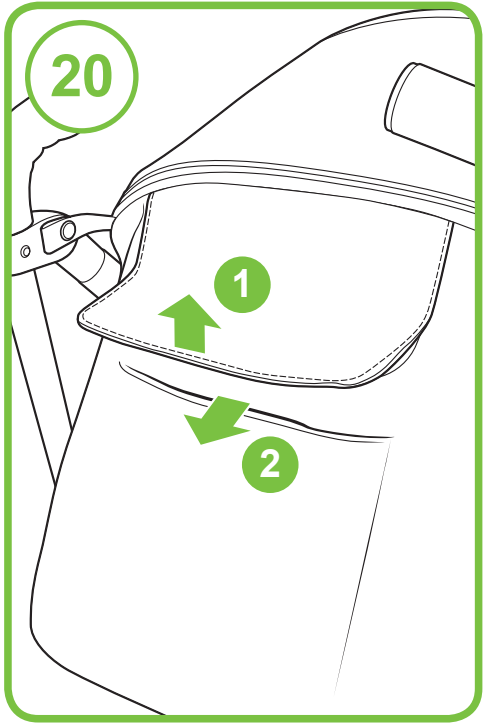
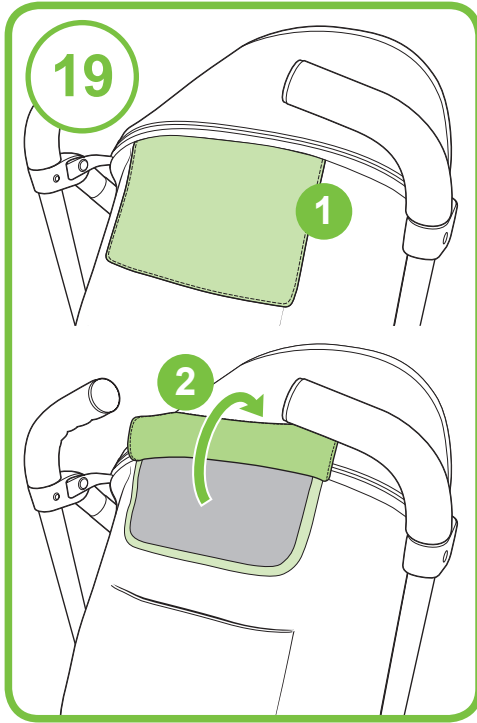

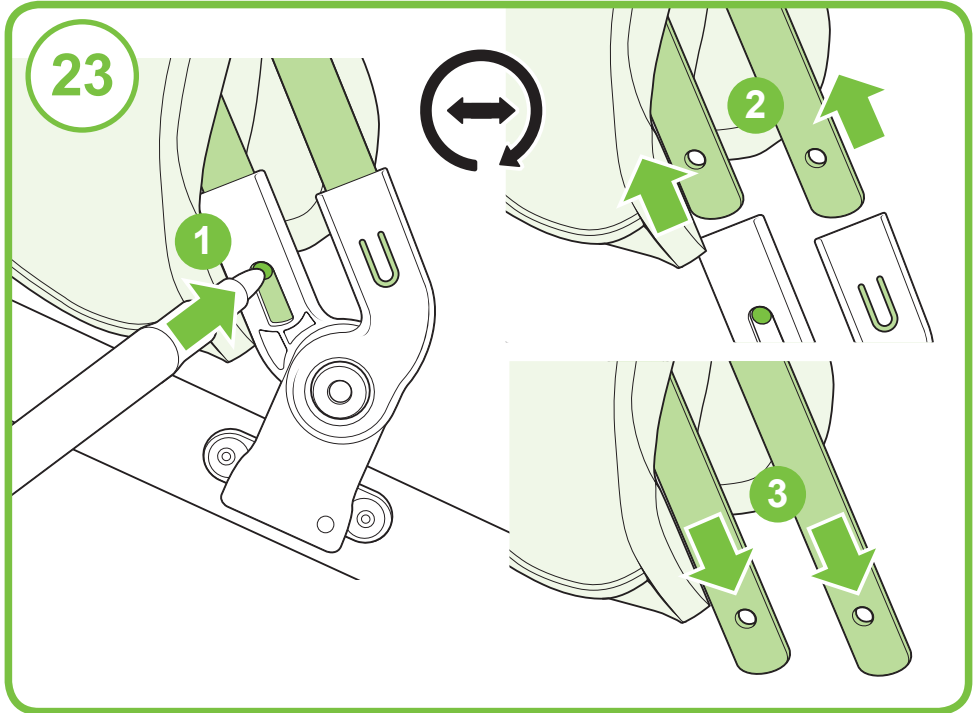
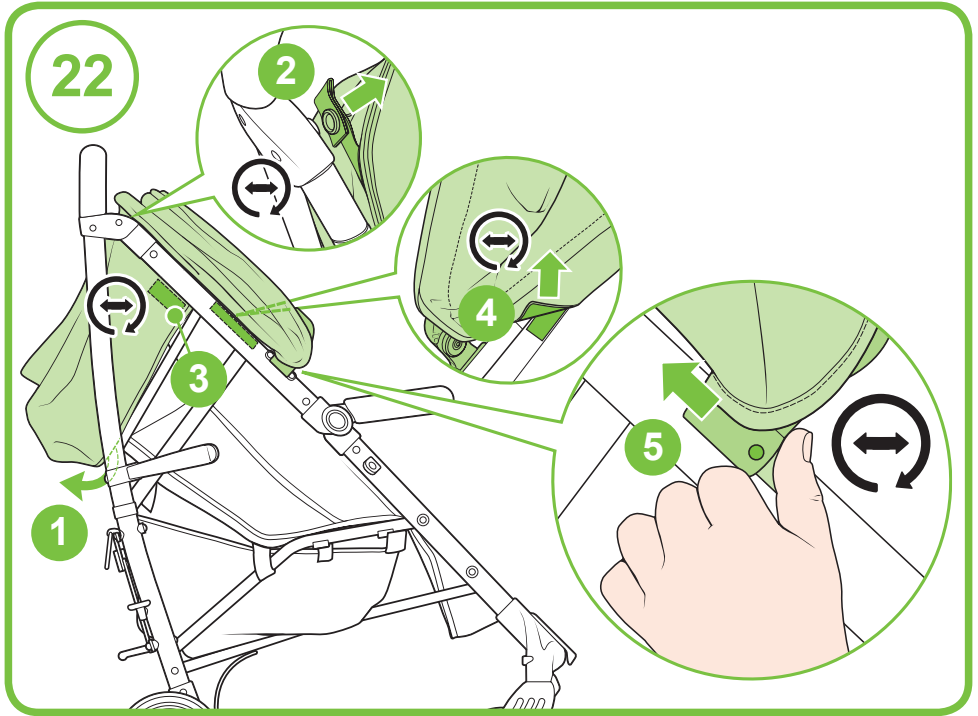

24

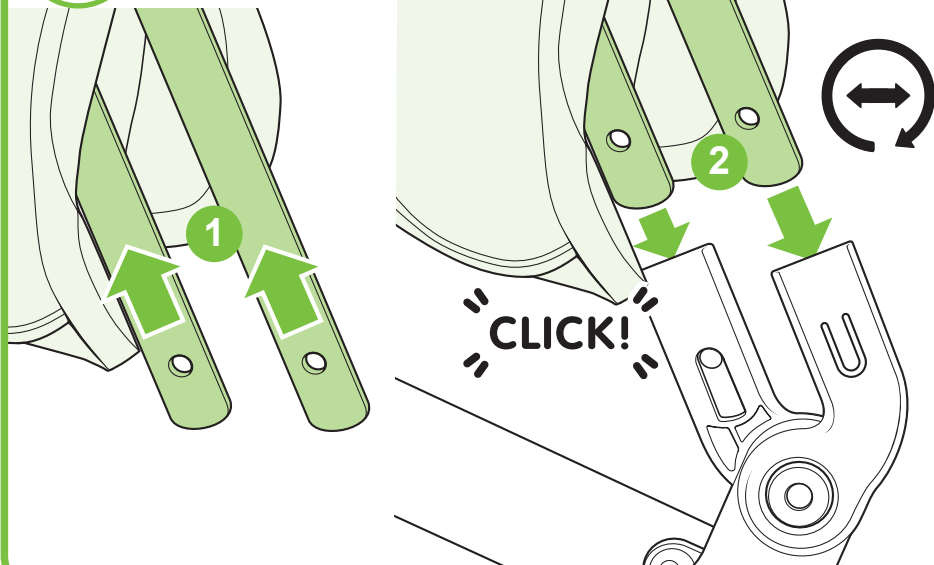

25

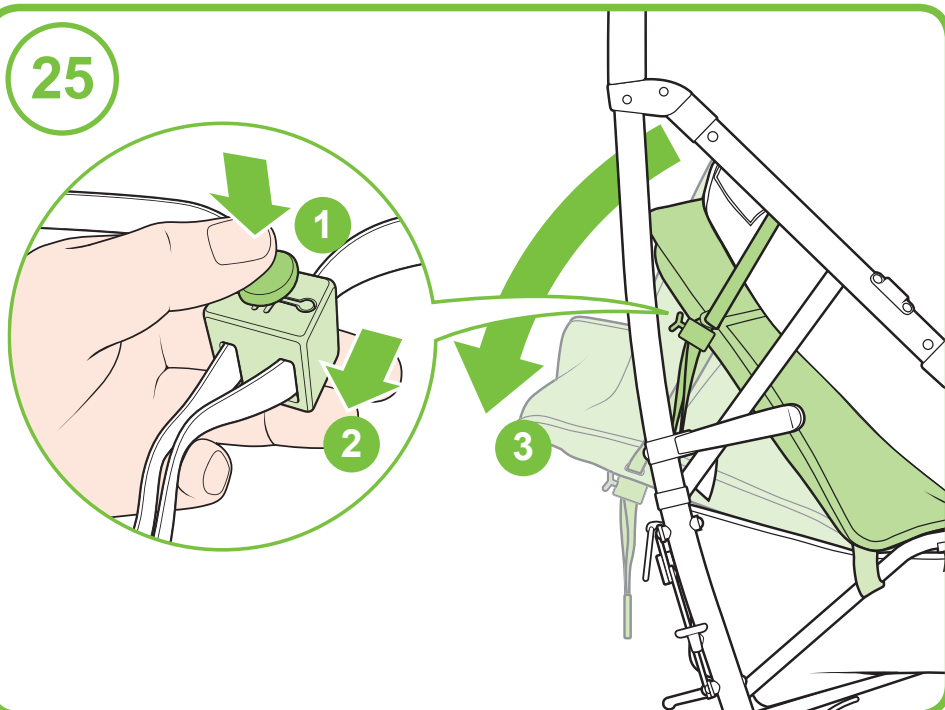

26

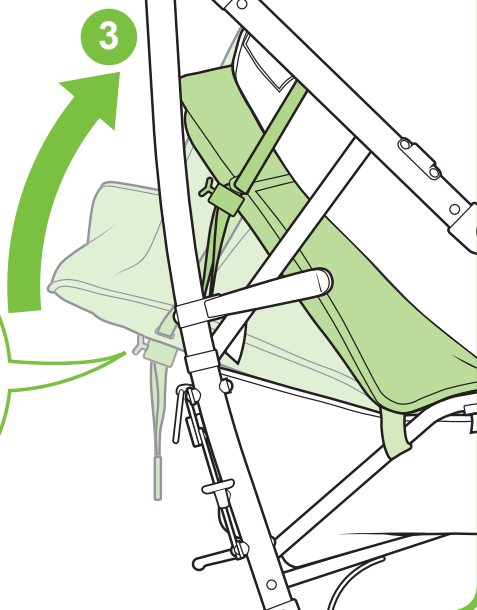
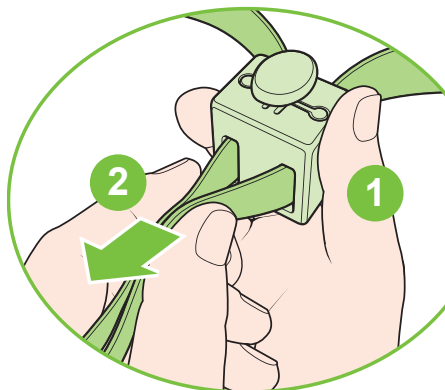

27

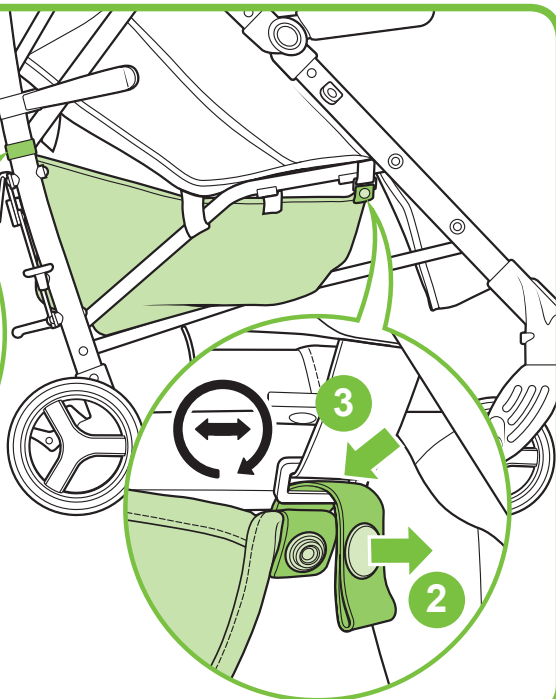

28

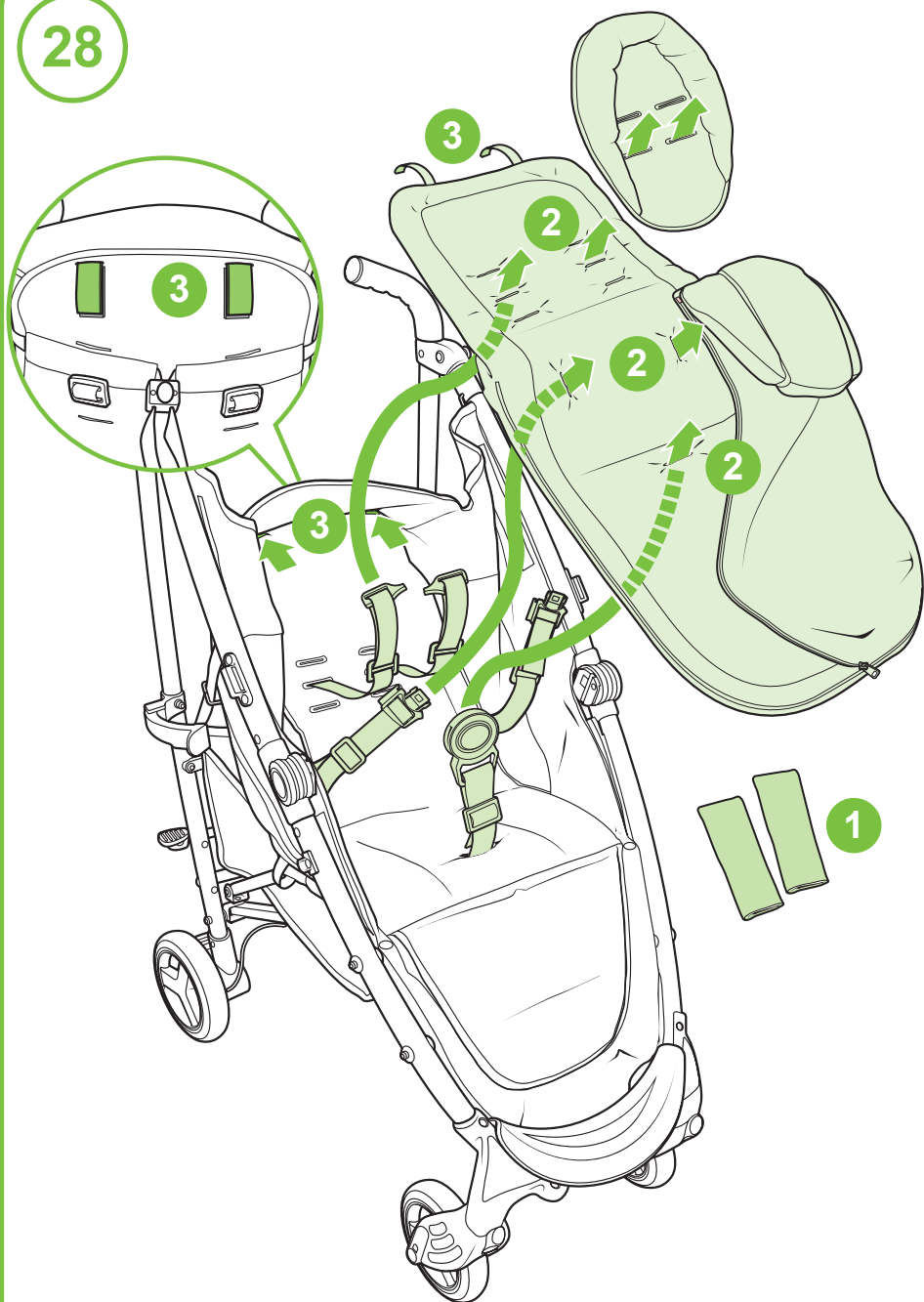

29

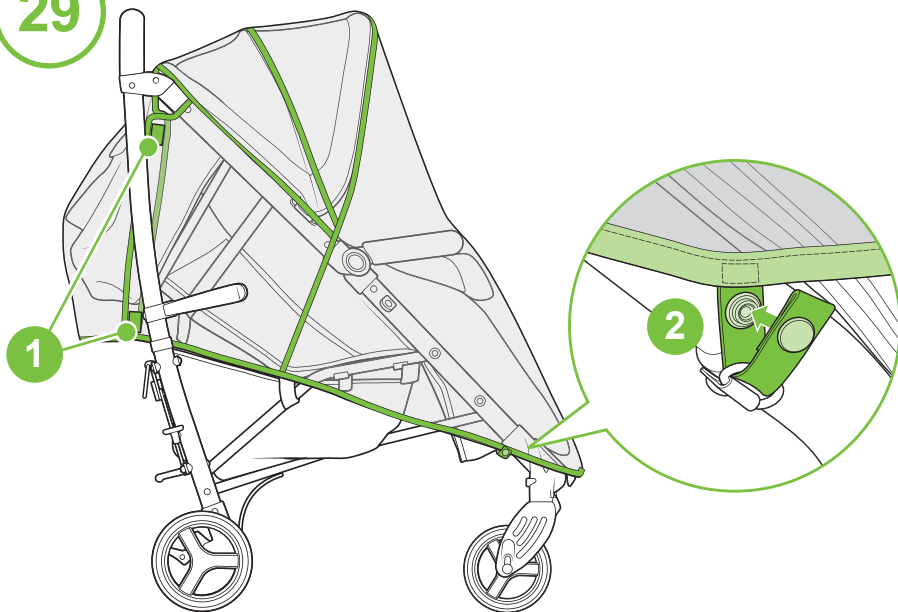

30

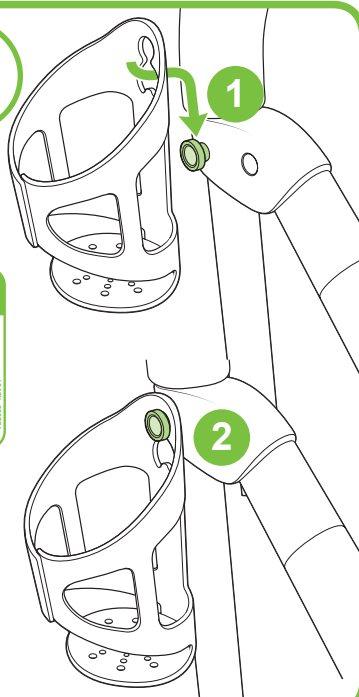

31

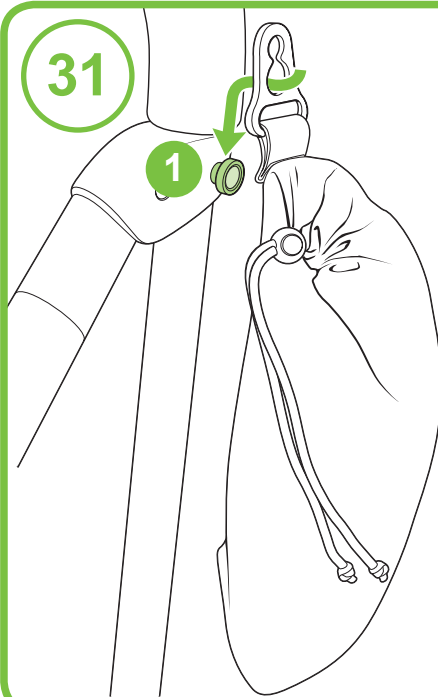

32

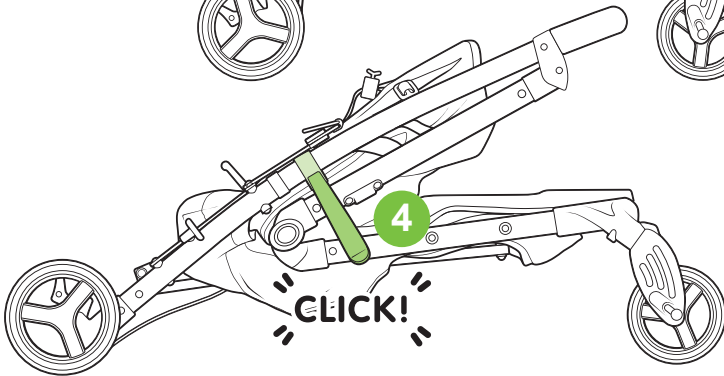
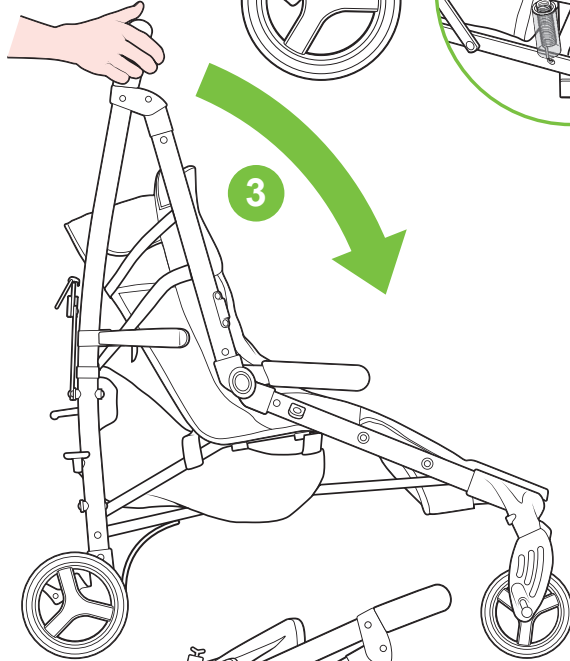
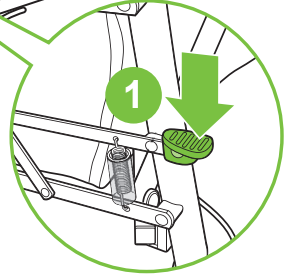
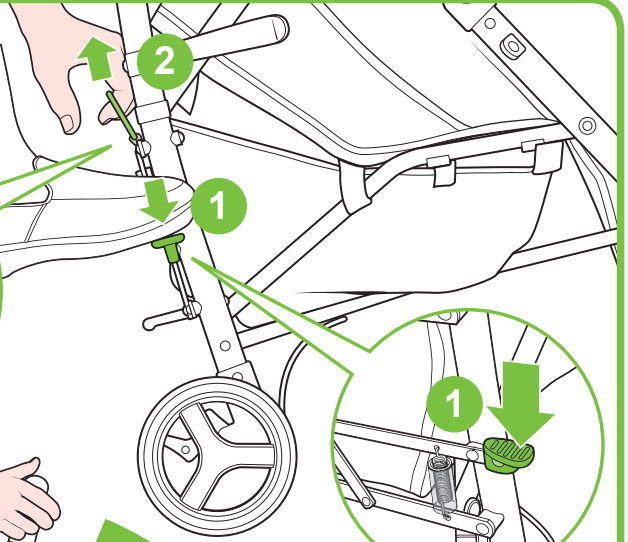
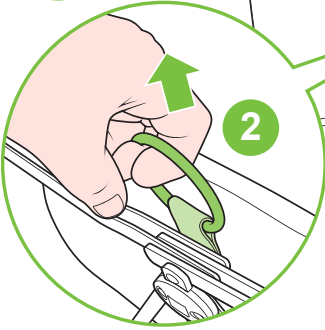

The background of the entire page is a repeating pattern of green geometric shapes, including triangles and rounded polygons, arranged in a symmetrical, sunburst-like pattern. A large white rectangle is centered on the page, containing text and a dotted line.

www.cosatto.com

Cosatto Ltd, Bentinck Mill, Bentinck Street, Farnworth, Bolton, BL4 7EP, England
UK FREEPHONE: 0800 014 9252* International T: +44 120 486 1007

Email: cuddle@cosatto.com

* Calls from BT landlines are free but calls from mobiles and other networks may vary

.....

All the design and trademarks contained herein are the property of Cosatto Limited.
No part of this document may be reproduced without the permission of Cosatto Limited.